

- [Home](#)
- [Association](#)
- [Community](#)
- [Photos](#)
- [Articles](#)
- [Help](#)

Search

Find! [Search this site](#) powered by [FreeFind](#)

C36 Basic Maintenance 101

Cleaning & lubricating the C36 winches

(for the newbie or mechanically-challenged owner)

by [Dennis Stovall](#)
7/12/2006

Man, those winches are powerful. We use them to haul up the mainsail, the jib sheets, to climb the mast, to haul gear on/off board... they work and work and seemingly never fail. But like all things in the sea, eventually the salt, the sun, and the weather takes it's toll.

Mary and I placed our factory order back in the fall of 1998. By April of '99, hull #1791 was delivered to a boat yard in Seattle. The four winches that came on our 1999 model included a pair of Lewmar 48ST winches (the big winches for the jib sheets) and on the cabin top were the Lewmar 30ST winches. Both are self-tailing, two-speed winches. Depending on the year of your C36, you may have different brand or model winches -- but Lewmars have been standard for a long time now.

By 2005 the speed of our winches began to slow down a bit, and I knew it was time

to open them up for cleaning & lubrication -- but my images of opening the winch and having springs go KER-SPRING, PLOP into the sea caused me to do the old, "Next year I'll...". So I dragged my feet and waited. Midway in Anuqa's 8th sailing season I accepted that it was a task I should not/could not put off any more, and I photographed each of the steps along the way.

Understand that I'd never opened a winch before, so I serviced the first three winches, and photographed the steps on the final winch (with my camera in my right hand, as I overhauled the winch with my left).

I. The basic tools



Lewmar makes a Winch Maintenance Kit. My local West Marine didn't have the kits in stock, so I did an internet search for "*Lewmar Winch Maintenance Kit*", found one at Boater's World for about \$23, and ordered it. Shipping USPS first class, the kit arrived in about 3 days. The Lewmar manufacturer number for his kit is **19701500**.

Lewmar also produces a "*Winch Repair Kit*".



The kit comes with a manual (in five languages), a tube of winch lube, a tube of winch oil, a brush, and a bag of pawl springs.

Honestly, all I wound up using was one page of the manual, and the winch lube & oil (oh, and one pawl spring). You can probably buy a tube of the winch lube for about eight bucks, use products you probably

already have on hand, and save a bit.



Besides the items in the kit, I used a roll of paper towels (about 1/2 roll was enough to complete all the winches), a few squirts from can of WD-40 for cleaning, and a screwdriver.

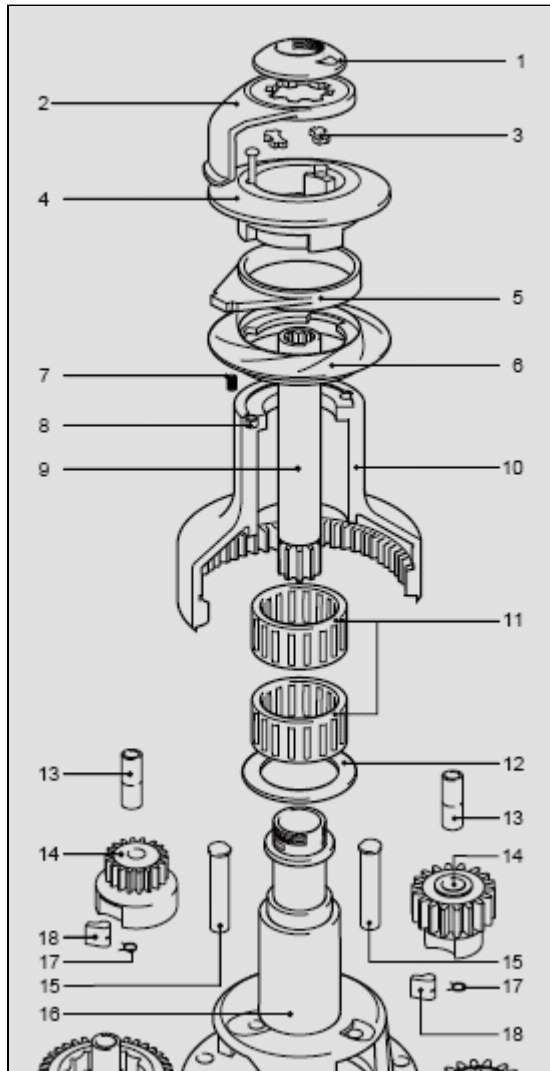

DON'T LET THIS INTIMIDATE YOU...

This chart is taken from the Lewmar manual that came with the maintenance kit. Items 7 and 8 are on the newer "Wavespring" winches - they weren't on mine. This is only provided so we have the names of the parts.

- 1 - O Ring
- 2. Feeder Arm
- 3. Collet
- 4. Upper Crown
- 5. Stripper Ring
- 6. Lower Crown
- 7. Spring (*not in my model*)
- 8. Spring cup (*not in my model*)
- 9. Main Spindle
- 10. Drum

11. Roller Bearing Assembly
12. Drub washer
13. Gear Spindle Sleeve
14. Pawl Gear
15. Gear Spindle
16. Center Stem
17. Pawl Spring
18. Pawl
19. Ratchet Gear



A cup of coffee is a probably good idea as you prepare to open the first winch. I like mine fully leaded, with a little Coffee Mate.

TIP: Whenever you're taking apart anything where you anticipate you'll soon be wondering, *Where the heck does this stupid thing go?* -- You can avoid much frustration by taking a few digital photos along the way -- especially at the very beginning. Then you can refer to the photos, if necessary, as you reassemble it.

II. Opening the winch



Rule of thumb is to cut a hole in a towel and placed it around the winch to catch any parts that may fall.

The *O-Ring* has a notch in it. Give it a counterclockwise push. I used the tip of the screwdriver. That worked okay, but it wasn't my brightest move. In retrospect, I'd suggest you use a piece of wood or maybe a pencil with the eraser into the notch. It only takes a quick nudge to loosen the *O-Ring*.

eraser into the notch. It only takes a quick nudge to loosen the *O-Ring*.

Tip from Tom Sokoloski: Can also use a cardboard box with a hole cut out, instead of a towel. The cardboard box bottom from a case of beer works well! :-)



Now spin off the *O-Ring*...

NOTE: According to Tom Sokoloski, earlier Lewmar winches have 4 phillips head screws on the top in place of the *O-ring*.



And lift the *O-Ring* off and place it on a towel.

I'd encourage you to have one towel on the seat to place the parts on. I tried to keep my parts in order as I removed them, to make reinstalling them easier.



Now lift off the *Feeder Arm* and place it on the towel.



Now you'll remove the *drum*.

It's a bit heavy.

Place the *drum* on the towel.

III. The cover's off... now what?



This is the inside of the winch. Take a moment to look it over.

At the top are two *collets*. For some reason, I think of them as keys. They fit into a groove in the stainless steel

spindle (inside).

Remove the *collets* and place them on the towel.



The tall bronze unit is called the *Center Stem*. Inside the Center Stem is the Spindle.

Now pull up on the Spindle...

NOTE: In the manual it's called *Centre Stem*. Not to worry -- our friends in the UK spell funny.



Pull out the spindle and place it on the towel.

That's my inspector dog, Conor, (a Wheaten Terrier) in the background. If only I could train him to take the photos...



Resting around the *Center Stem* should be two roller bearing assemblies, a black *washer*, and possibly a black *spacer* between the *roller bearing assemblies*.

If you don't find two sets of roller bearing assemblies, look inside the drum. One or both of them may be inside the drum -- attached by sticky grease. If they're in the drum, just reach in and pull them out.

Place the roller bearing assemblies on the towel.



And now remove the black *washer* and place it on the towel.



For a 2-speed winch you'll have two sets of *gears*.

Use a flat tip screwdriver to pull up on the *Gear Spindle*...



Once the *Gear Spindle* comes up about 1/4" or so, you can pull it out with your fingers.

You need remove the Gear Spindle so you'll be able to remove the gears for cleaning.

Place the Gear Spindle on the towel.

If you're worried about getting confused with all the parts on the towel, so was I... so on my winches, I only removed one Gear Spindle and one set of gears at a time -- removing, cleaning,

lubing, and replacing it, before I removed the second set.



Wiggle out the gear assembly and place it on the towel.



Underneath the gear assembly you'll probably see some crud that needs to be cleaned out.



There are lots of cleaners/degreasers out there. I found a little WD-40 sprayed on a paper towel did a good job of cleaning off the crud.



Now just work in the towel towel & cleaner to remove the old grease.

You could also use a toothbrush or rag and any other metal cleaner.



I used WD-40 and paper towel to clean off the *Center Stem* as well.



Once the Center Stem and base unit is cleaned to your satisfaction, take a look at

your gear assembly. It's actually one geared mechanism that fits inside another -- with two pawls inside that allow the gears to work together.



Lift up on the top/smaller gear and remove it from the larger one...



Inside the smaller gear (left of photo), you'll see the two pawls -- they're like levers that go in and out, fitting in notches in the larger bottom gear.

NOTE: On some winches the pawl springs are not symmetrical - they fit into the pawls only one way. One "tail" of the spring is straight, the other is curved. Check as you take them out.



This is another view of the larger gear.



Each pawl can be removed. Inside each pawl is a small spring. The spring fits in the slot in the pawl, and the pawl presses into the gear. The pawl spring makes the pawl open/close so the gearing system functions.

IMPORTANT TIP from Tom Sokoloski: The pawls and pawl springs should NOT be lubed with grease. Use only a light oil, so the pawls will not stick as the grease hardens with age. Use winch oil, 3-in-1 Oil, or similar.



In the Lewmar kit there's a bag of *pawl springs*.



This photo is kind of blurry, but you can see the spring near the tip of my middle finger.



The spring just drops into the pawl...



And using your fingers, the *pawl spring* and *pawl* are simply slid or pressed into the gear.

NOTE: To lubricate the pawls, make sure you apply oil, and not winch grease. The grease can eventually cause the pawls to stick -- oil will prevent this.



Clean out the gear pieces using a cleaner and some sort of brush.

When it's clean to your satisfaction, squeeze about 1/2" of the Lewmar winch lube on your finger...



And coat the entire gear section in the lubricant.



When both sections of the gear assembly are cleaned and lubed, squeeze in the pawls and place the pieces back together.



If you haven't done so already, make sure the bottom of the *Center Spindle*

also has a coating of lubricant...



And set the *gear assembly* back in place.

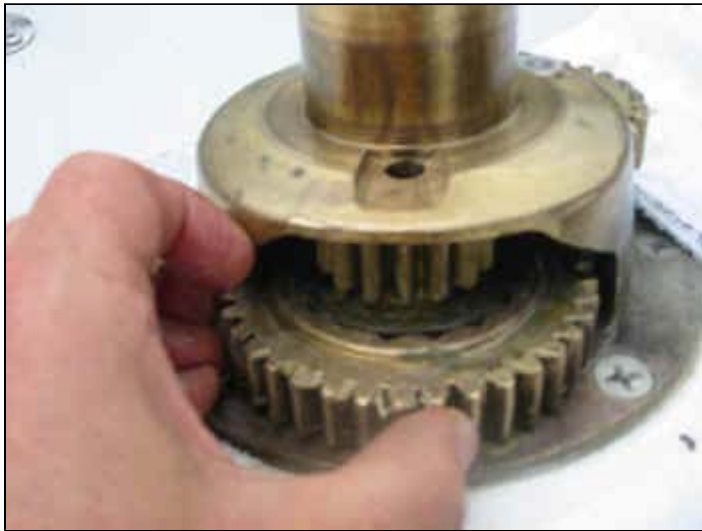

There will be a slight notch as the gear fits in correctly.



Now take the *Gear Spindle Sleeve*, put on a coating of

lubricant...



And press the *sleeve* into the gear assembly.

NOTE: There's an indentation at one side of the sleeve -- that indentation goes next to the center stem.



You'll probably need to wiggle it a bit as it fits in.

Okay, this leads to at least 3000 possible jokes -- all of which I choose to ignore. If you know me very well, you know the pain I'm in trying to hold back on this.

IV. Now that you know what you're doing...

Excellent, you've finished the first of the gear assemblies. The second one should go quite a bit faster. I'll pick up the pace a bit as we go straight to removing & cleaning the second gear assembly...



First, remove the *Gear Spindle*.



Remove the *gear assembly*.



And place the gear assembly on the towel.



Check the bottom of the Center Spindle for dirt/crud.



And using some cleaner and a towel,



Clean out the other side of the housing for the gear assembly,

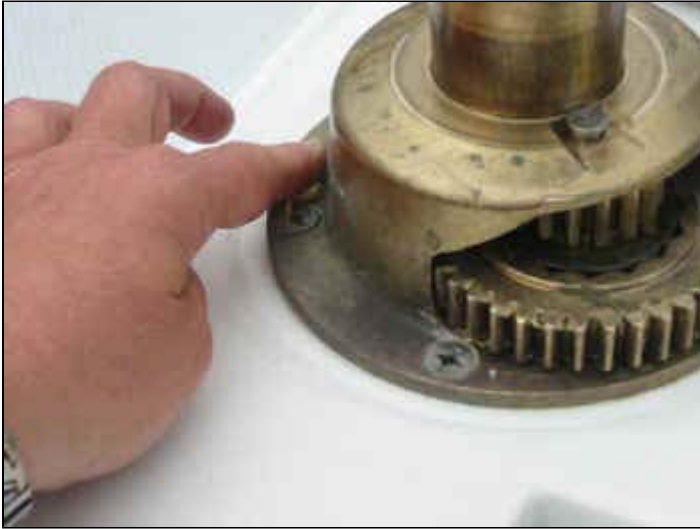

And apply a coating of lubricant/gear grease.



Pull out the top/smaller gear,



and check the pawl springs to make sure they move in and out freely.



Again, to test them, just squeeze the pawls in and out...



Squeezing them in and out a couple of times, they should work easily.

NOTE: Make sure you apply oil the pawls, and NOT winch grease (which can eventually cause the pawls to stick).



Remove old grease and clean each gear...



Apply a coating of lubricant...



all over each piece,



And reassemble it by pressing in the pawls



And pressing the parts together.



This one's clean and ready to go.



Replace the gear assembly



Replace the *Gear Spindle* so it's fully seated.



Note: The tops of the gear spindles should be at the same height as the base of the center stem.



Now add a coating of lubricant to the center stem.



Clean and lubricate the main spindle.



Place the main spindle back in the center stem (with the geared side down).



Clean and lubricate the *collets*, and place them into the slot of the *main spindle*.

NOTE: This may take two hands -- one to pull up slightly on the spindle as you fit the collets in.



This is the center stem with the gears in place -- all cleaned and lubricated.

Hang on -- we're getting close to being done.

V. AGH! I have all these parts left over!!



Take a sip of your coffee and breath deeply. What you're

down to are the two roller bearing assemblies, the washer, and the spacer.

The 48ST has a spacer that goes between the roller bearings -- not every winch has a spacer.



Clean and lube the washer...



and place it over the center stem, pressing it down as far as it will go.



Clean and lube the one of the

roller bearing assemblies



place it over the center stem



and push it down in place.

Now add the spacer, and the second roller bearing assembly -- cleaned and lubed.



Take a few minutes to clean

and lube the inside of the housing...



that includes all the notches that will fit against the gear assemblies...



And inside -- especially those areas that will go against the roller bearings.



Pick up the drum and

prepare to set it in place...



Sliding the drum over the winch gears and spindle.

In the background is our other dog, Uncle Sam (he was born on the 4th of July). Sam is a Scottish Terrier.

VI. Almost done



ONLY TWO PIECES
LEFT...

That funny piece with the
self-tailer is next. It's called
the *feeder arm*.



Now clean off the Feeder
Arm and apply a coating of
lubricant in the center area.



This can be a little tricky,
because the Feeder Arm has
to fit around the collets.

If the collets work their way
out, you'll have to press them
back into the main spindle or
the Feeder Arm won't fit.

NOTE: The self tailer (the little bent part) must be inboard.



Put a little lube on the inside/grooves of the O Ring and hand thread it back on.



And that's it.

Take a winch handle and test it by working it, turning the winch both clockwise and counterclockwise several turns.



Take your rags and towels and toss them the trash.

VII. Final inspection



Make sure you get an official nod of approval from your own Inspector Dog before you consider the project done.



And as a final step, take a little *Never Dull* or *Brasso* (or other stainless cleaner) and polish off the outside to remove any remaining grease or surface pits and you're done.

Total time

Figure one hour for your first winch (if you've never done one before), and about 20-30 minutes per winch for the others. That means you can do all four winches in under two hours. I know, you don't believe it. And I didn't believe **Bill Harvey** last month when he told me either, but it's a much simpler job than it sounds.

Total Cost

This is a cheap maintenance job for an owner to do. Even if you purchase the entire Lewmar kit, it's still **less than \$25** (subsequent cleanings will be the cost of a tube of lubricant, just under \$10). Either will do all four winches, and maybe a couple of times. Other items used, e.g. the WD-40 and paper towels or rags, these are incidentals that every boat owner keeps on board anyway.

How often should I clean the winches?

More often than every 8 years, that's for sure. It's a relatively simple job after you do it the first time. Ideally the winches should be cleaned every spring.



ALSO...

C36 owner **Steven Jones** created a 2-page PDF that sums up all these steps -- the PDF is perfect for printing out and carrying to your boat. For a copy of Steve's PDF, [click here](#).

Copyright (c) Catalina 36 International Association