

Evaluating Modern Anchors and Ground Tackle

Dave & Sherry McCampbell

www.SVSoggypaws.com

Link to Presentations on Home Page

Update 7-28-2021

Raroia Atoll,
French Polynesia

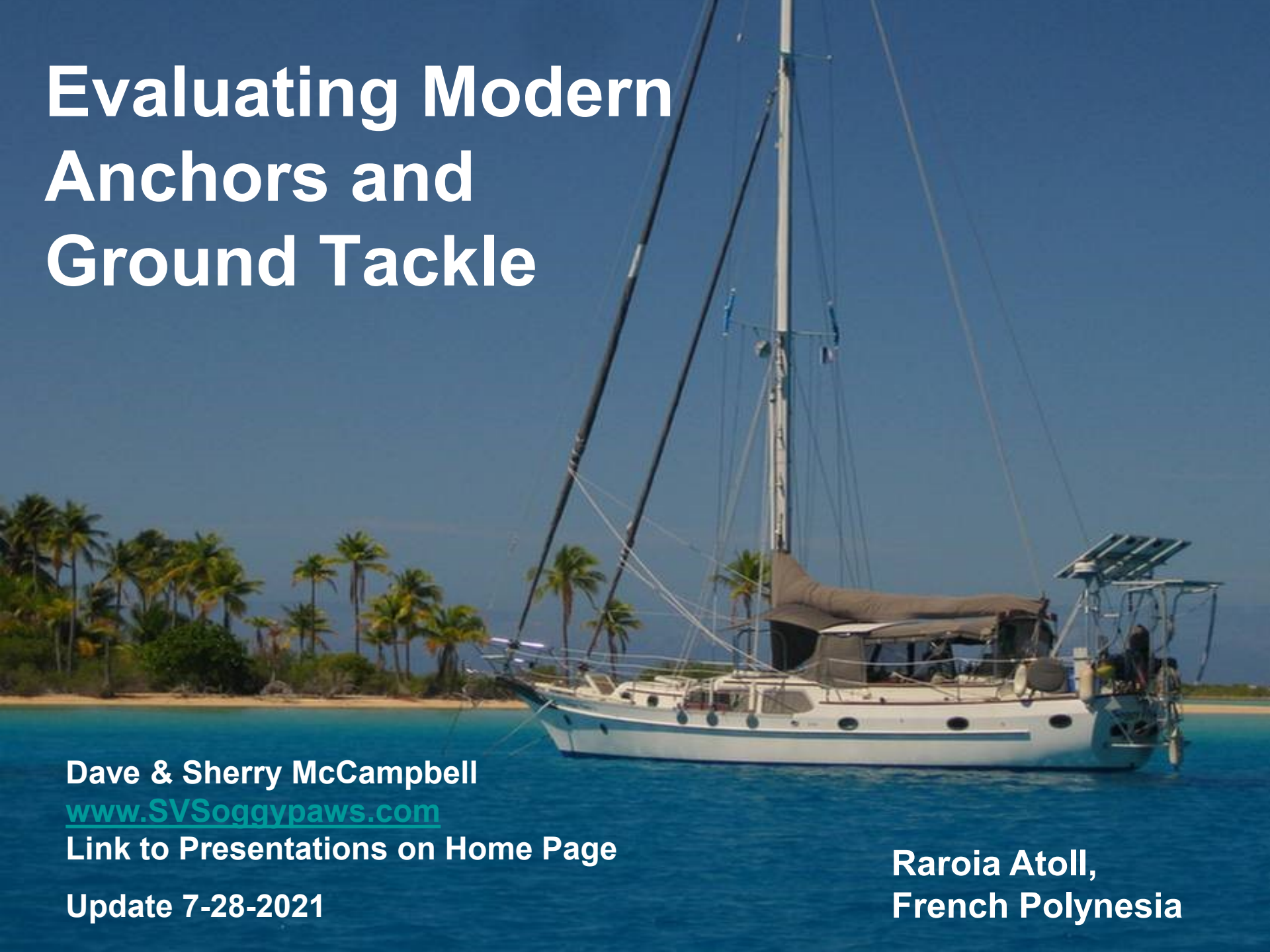

Basic Outline



- Loads Pgs 3-8
- Ground Tackle Pgs 9-57 (Q&A)
- Anchors Pgs 59-171 (Q&A)
- Storm Anchoring Pgs 172-178
- References Pgs 179-186
- End Pg 187 Q & A

Ground Tackle Engineering

- Why we need strong ground tackle
- Wind Loads
- Other Loads
- Bottom Coefficients
- Scope and Catenary

Wind Loads

**If wind speed doubles,
loads quadruple!!**

**Hurricane
Katrina in FL
Keys 2005**



CSY 44 Load from Wind Only

FORCES.WK4

ANCHOR FORCES CALCULATION

Assumptions: CSY 44 with Wind Resistance (WR) of 243 sq. ft.

Wind Pressure $WP = C_d \times P/2 \times V^{**2} \times WR$

C_d = Coefficient of vessel drag...assume 1.1

P = Air density...assume .0034

V = wind velocity

Thus, $WP = V^{**2} \times .454$ (lbs)

Wind pressure is the force on a single anchor (assuming no significant current)

V	SINGLE		TWO ANCHORS ACROSS THE WIND					
	WP	F with a=	F with a=	F with a=	F with a=	F with a=	F with a=	
10	45	10	20	30	45	60	75	
20	182	131	66	45	32	26	24	
30	<u>409</u>	523	266	182	129	105	94	
40	727	1178	598	409	289	236	212	
50	1136	2093	1063	727	514	420	376	
60	<u>1636</u>	3271	1661	1136	803	656	588	
70	2227	4710	2391	1636	1157	944	847	
80	2908	6411	3255	2227	1574	1286	1153	
90	3681	8374	4251	2908	2056	1679	1505	
100	4544	10598	5381	3681	2603	2125	1905	
110	5498	13084	6643	4544	3213	2623	2352	
120	6543	15832	8038	5498	3888	3174	2846	
130	7679	18841	9566	6543	4627	3778	3387	
		22112	11226	7679	5430	4434	3975	

However, if the boat is anchored in Bahamian moor style, with the wind perpendicular to the (imaginary) line between the two anchors, then the force on each anchor is:

$$F = WP / (2\sin a)$$

If $a=0$, F is infinite (assuming no rode stretch)

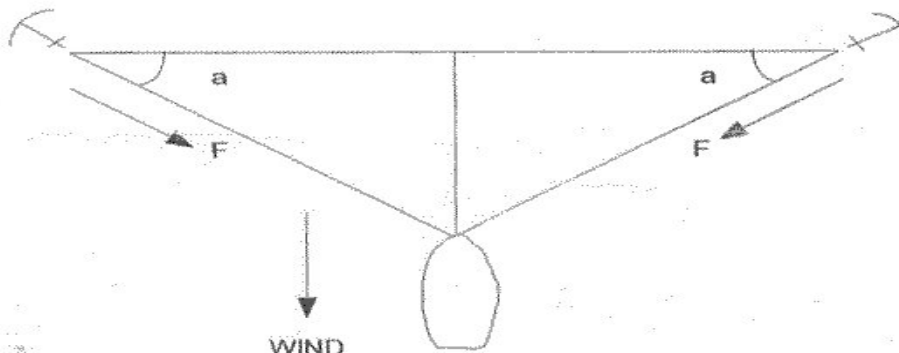

Load on Anchor

Wind Pressure Only – CSY 44

Wind Spd	Force on 1 anchor	Force 2 @ 45°
10 kt	45 lb	32 lb
30 kt	409 lb	289 lb
60 kt	1636 lb	1157 lb
90 kt	3681 lb	2603 lb
120 kt	6543 lb	4627 lb

- Straight line wind pressure only!
- Must add yaw, pitch & shock loads
- 30 kts > 60 kts quadruples the load on the anchor!

Total Loads

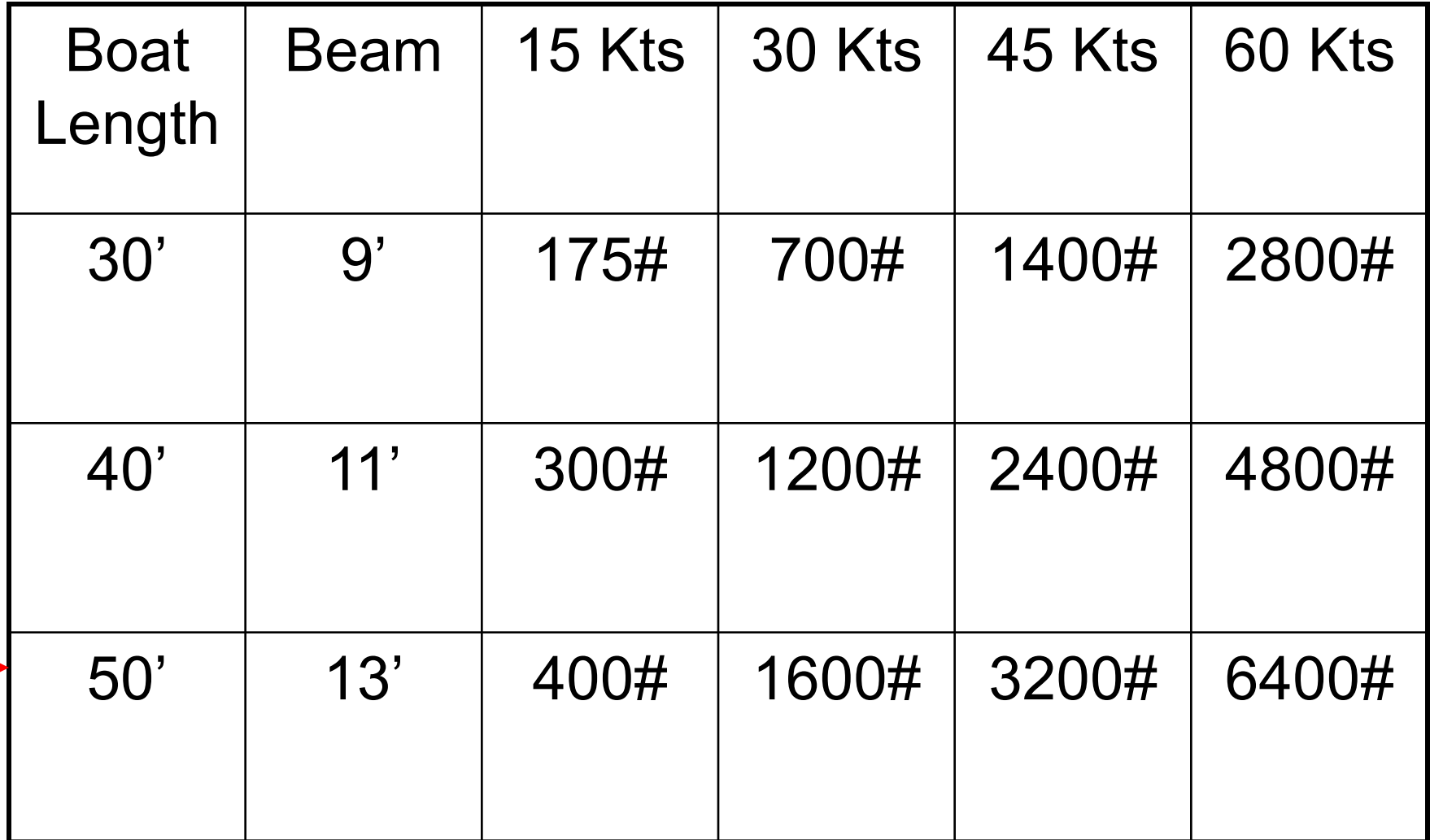

Boat Length	Beam	15 Kts	30 Kts	45 Kts	60 Kts
30'	9'	175#	700#	1400#	2800#
40'	11'	300#	1200#	2400#	4800#
50'	13'	400#	1600#	3200#	6400#

From ABYC/Calder. Includes wind, wave action, yaw and shock loads!

Bottom Holding Coefficients (Coefficient of Friction)

TABLE I-2. ESTIMATED HOLDING COEFFICIENTS FOR VARIOUS TYPES OF SEAFLOORS

Material	Dense Clay	Dense Sand	Silt	Soft Mud	Coarse Sand	Pebbles	Rocks
Particle size	<4 μ	0.06–0.6 mm	6–20 μ	4–63 μ	0.6–2 mm	6–20 mm	>20 mm
Holding coefficient	1.50	1.00	0.65	0.45	0.40	0.35	0.00



Better Holding ----- Worse Holding

3X greater holding power in dense clay vs soft mud!

Scope and Catenary

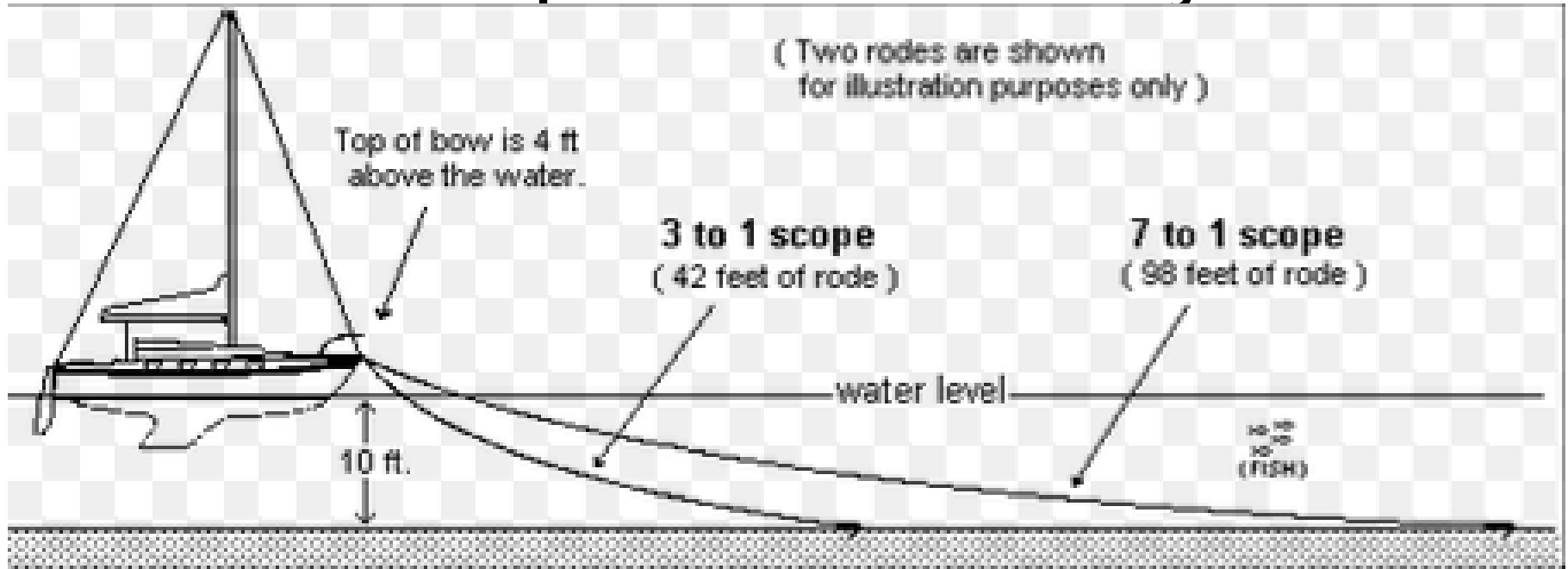

Height = water depth + high tide diff + bow roller height

Scope = ratio, rode out / height

Chain Catenary - absorbs shock loads, when shank lifts no more catenary

Bruce's Law - critical (no catenary) load on anchor equals scope times the weight of chain deployed.

Example: 3/8" chain (1.5lbs/ft) : 3x60lbs=180 lbs 7x150lbs=1050 lbs

Bottom Line – For heavier winds use more scope (a minimum of 5:1), **but no less than 70' of rode REGARDLESS of depth.**

GROUND TACKLE

- Finding Weak Links
- Chain
- Line & Chafe Gear
- Snubbers
- Swivels
- Roller Trays

Ground Tackle Considerations

- ‘Bigger is MUCH better when it comes to anchors’
- ‘Regarding rode, more is better and chain is better’
- ‘An electric windlass is not just a luxury, it is a necessity, especially for us older folks’
- ‘Cruisers can’t afford cheap gear, especially when it comes to ground tackle’

Finding Ground Tackle Weak Links



- Chain 3/8":

– 3B/Proof	\$5	2650#
– HT/G4	\$5	5400#
– HT/G7	\$10	6600#
- Shackles:

– 3/8" MS/SS		2000#
– 7/16" MS/SS		3000#
– 1/2" MS/SS		4000#
– 7/16" G4	\$12	5300#
– 5/8" MS/SS		6500#
- Swivels:

– 1/2" MS	\$39	3600#
– 5/8" MS	\$58	5200#
– Kong 1/2" SS	\$240	6600# ¹²

Chain



SOTRA ANCHOR & CHAIN has become known as the world's largest stockist of anchors and chains. The company have today more than 10 000 tonnes brand new and second hand anchors, chain, shackles and accessories for supply within shipping, offshore, aquaculture, shipyards and even to decoration market.

Chain

- **Types-**
 - BBB/Proof - weaker
 - Stainless steel - weaker
 - HT - G4/G7 - stronger
 - Compare break strengths
- **Break Str = 3 - 4 x SWL**
- **Galvanizing**
 - Hot dip - Yes
 - Hot flame/cold spray - No
- **Buy quality calibrated-**
 - US- Acco/Campbell/Peerless
 - Italian/Australian
 - Chinese – don't buy
- **Must match chain gypsy**
- **If links are not stamped don't buy!**



Line Facts



- **Stretch-**
 - Nylon ~10-20% @ SWL
 - Polyester 2.4% or less @ SWL
- **Strength-**
- **SWL = 10-20% Break Load**
 - Polyester stronger than nylon
 - Polypropylene- floats, usable but weaker
 - Bigger is stronger, but less stretch
- **Abrasion resistance-**
 - Polyester better than nylon
- **Knot strength-**
 - **Bowline 60%**
 - Buntline hitch 85%
 - Splice 90+%
 - See www.bethandevans.com/load.htm
- **Thimbles-** better than soft eyes
- **Best rode line-** Braided nylon, best energy absorption & no twist!

Chafe Gear



- Problem - movement causes heat & chafe!
- Polyester - less stretch minimizes movement
- Must ventilate & protect line
- Options:
 - 1 Rags/towels/carpet/etc
 - 2 Fire hose
 - 3 Commercial - polyester, rubber, nylon, leather
 - 4 PVC hose – upsize, holes
 - 5 Combination poly - nylon
 - 6 Chain – no chafe

Snubber Lines for Chain Rodes



- **Attachment -**
 - **Bridle** – monohull chafe at chocks/stem
 - **Bow stem eye** – significant chafe at chain loop, not for heavy winds
 - **Over anchor roller** – best option w/ least chafe, reduces yaw
 - **Cats** - should use bridles, no chafe
- **Materials -**
 - **Options** - nylon, polyester, other
 - **Single braided nylon** - best strength/stretch combo
- **Length** – 35' optimal, allows adjustment for shallow & deep

Monohull Bridle Snubber Chafe

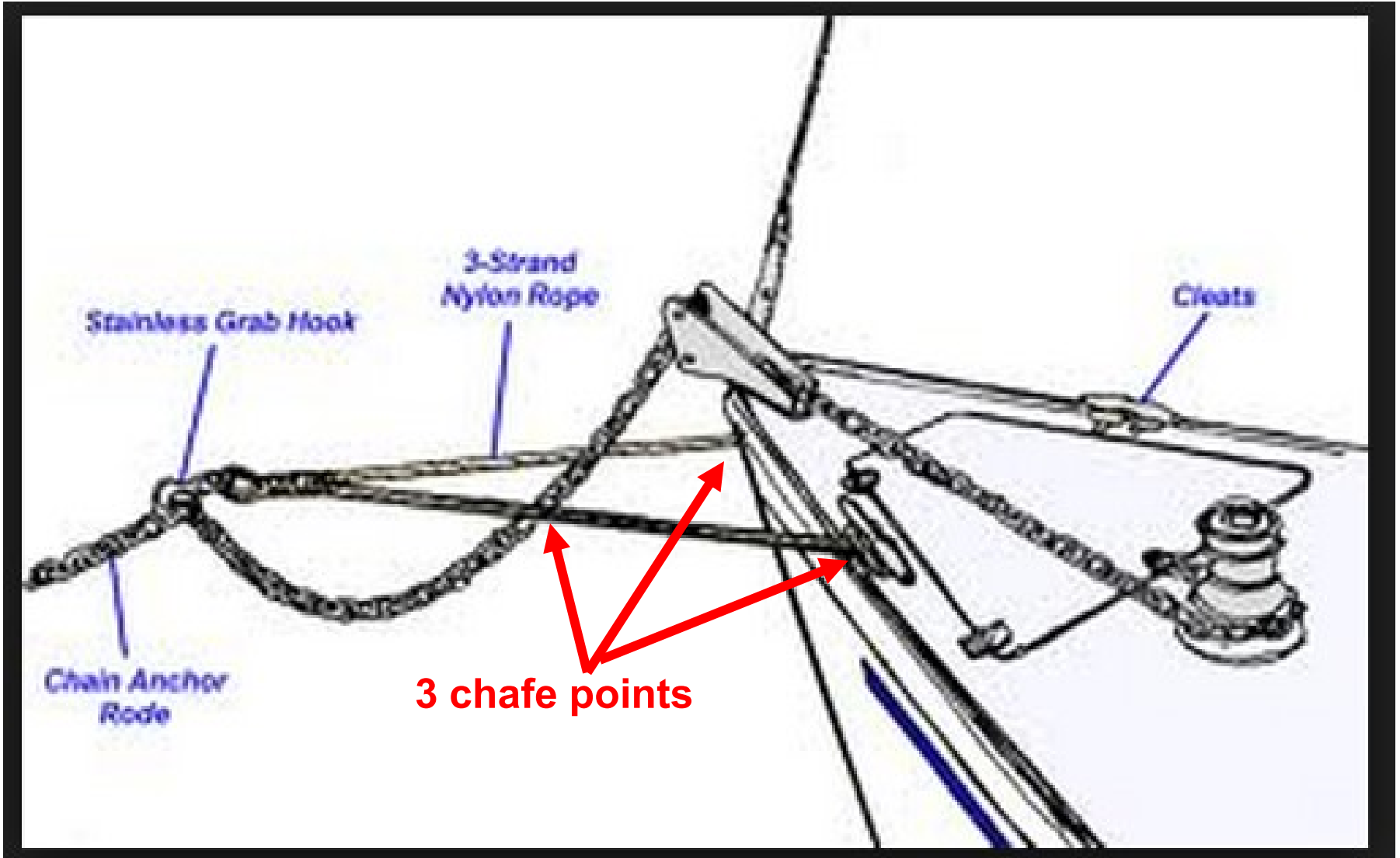

Snubber Connection Options



- **Chain hooks** - can drop off if open, most weak for HT
- **Claws** - good design, even chain pull, some weak
- **Knots** – slip, slow removal
- **Shackles** – slow removal, tool required, poss pin loss
- **U plates** –slow removal, strong/secure
- **Soft Shackle** – Amsteel, may be best solution

Chain Hooks

Most common attachment option

Most weak for G4 chain

Can fall off chain especially if used in shallow water

OK for light wind or day anchoring

May damage chain due to off center pull

Wichard more secure but eye looks really weak

Galvanized corrode quickly



Knots



Kong SS Chain Shackle



Nice design, slow disconnect w/ tool, not full strength for HT chain

ABI SS U Plate Connector

Multiple ways to rig,
shown seized loop in
bridle eliminates knots

Full strength, slow to remove w/ tool



Four Chain Claws



Yacht
Services



All weak
for HT
chain

Winch
Solutions



Seafit

Quickline Ultra SS Chain Grab

Great design, nearly full strength for HT chain, quick to remove, secure, but very expensive

High strength harp for securing snubber line exerts pull in line with direction of load on chain

Spherical dish holds an individual chain link without deforming the link and reducing the breaking strength of the chain

Harp length is designed to clear next link to allow release when load is picked up by chain

Full opening makes it easy to attach and detach even when chain is under tension

Bridge between halves provides strength
Ultra Chain Grab is stronger than chain

Round dish prevents catching while Ultra Chain Grab passes through and over the roller

Made of 316L stainless steel

Narrowed grab angle prevents catching until required

Quickline Ultra Snubbers

Rubber snubbers add stretch,
see Nov 2014 Pract Sailor



**Brait/Single braid
line, 8/12 strand**

**Run both lines over anchor roller
to different cleats, spreads the
load but reduces stretch**

Chain Grab Bridle with Sp

Mantus Chain Hook

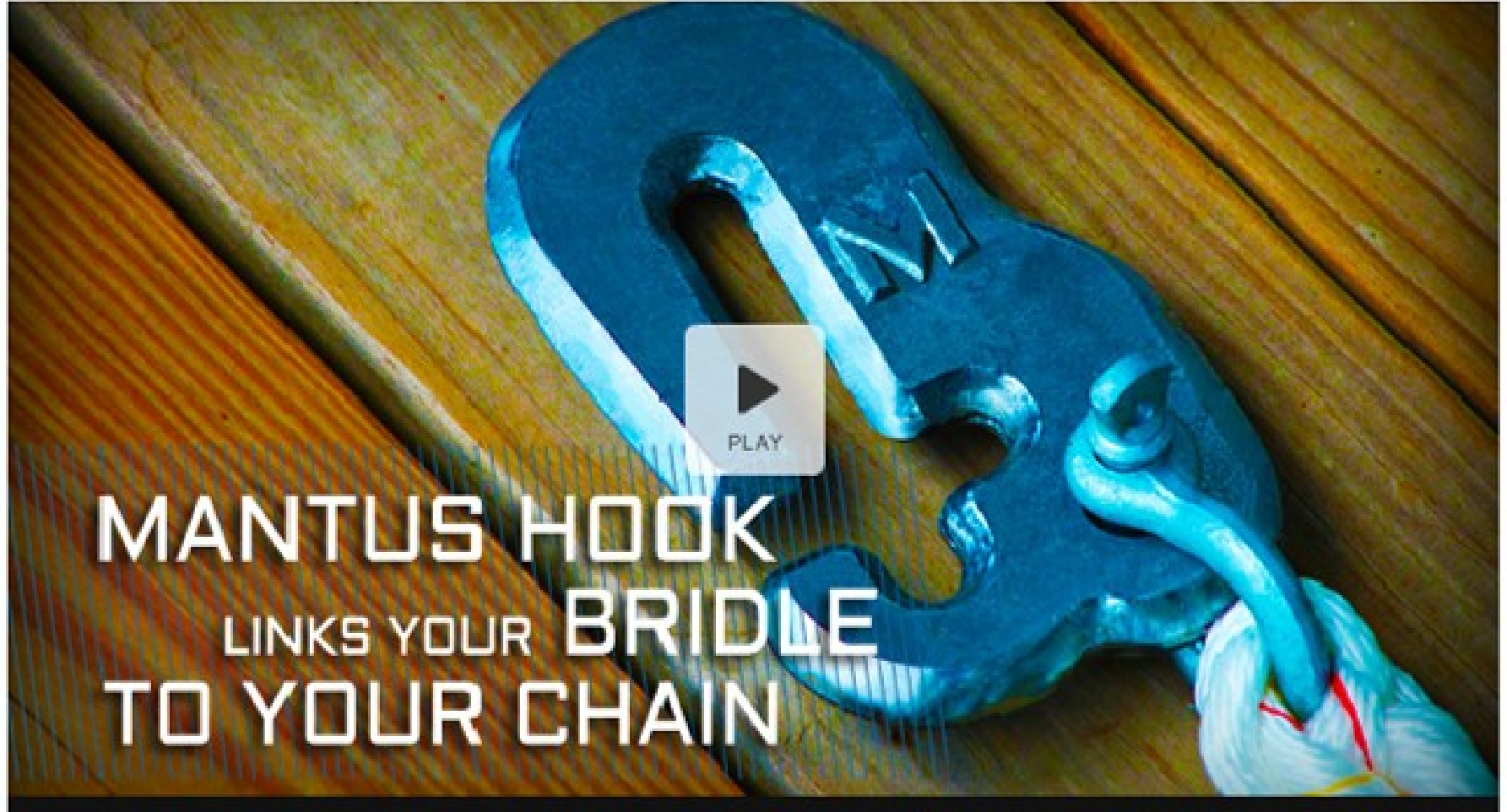

MANTUS HOOK
LINKS YOUR BRIDLE
TO YOUR CHAIN

Well designed, full strength for HT chain, can slip off without plastic gate, reasonable price

Mantus Chain Hook



Very secure with
locking plastic gate,
difficult to get over
some rollers, 3/8" SS
\$70



Soft Shackle Snubber Chain Attachment

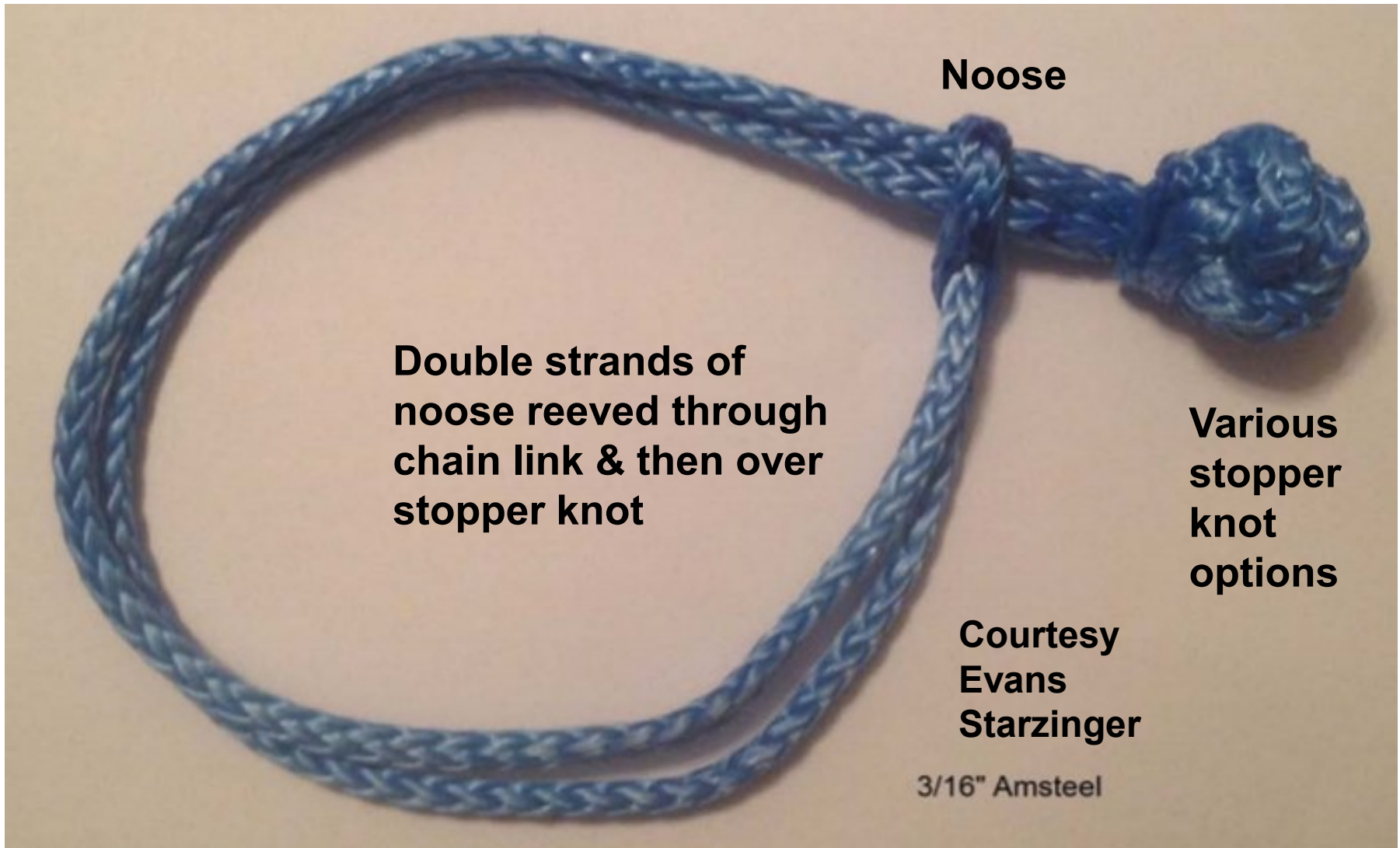

Noose

Double strands of
noose reeved through
chain link & then over
stopper knot

Various
stopper
knot
options

Courtesy
Evans
Starzinger

3/16" Amsteel

Amsteel Soft Shackle

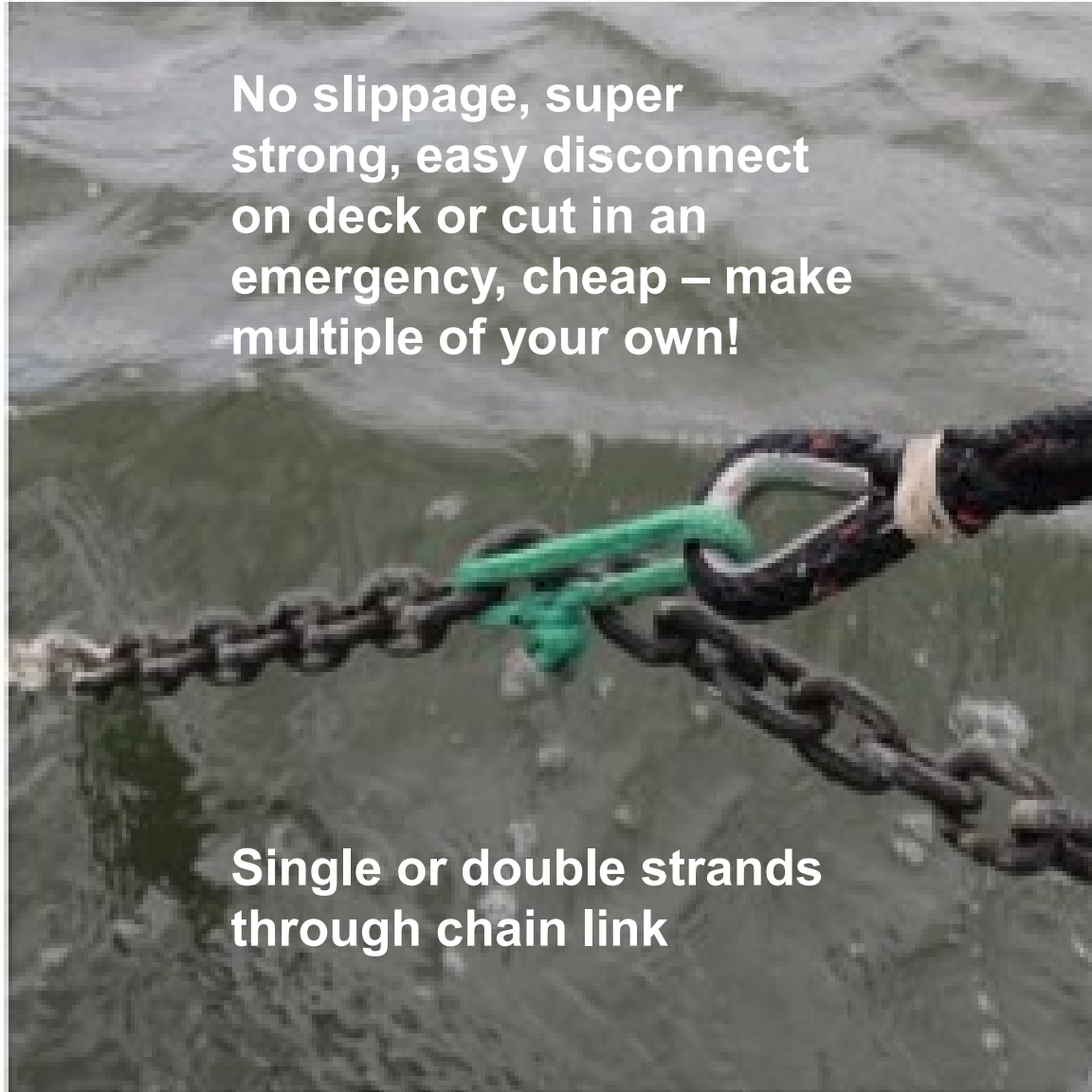

No slippage, super strong, easy disconnect on deck or cut in an emergency, cheap – make multiple of your own!

Single or double strands through chain link

Courtesy Evans & Beth Starzinger, see:

<http://www.bethandevans.com/pdf/snubber.pdf>

<http://www.bethandevans.com/pdf/improvedsoftshackle.pdf>

<http://www.bethandevans.com/load.htm>

Shockles Anchor Snubber

Not much help, expensive,
see Nov 14 PS

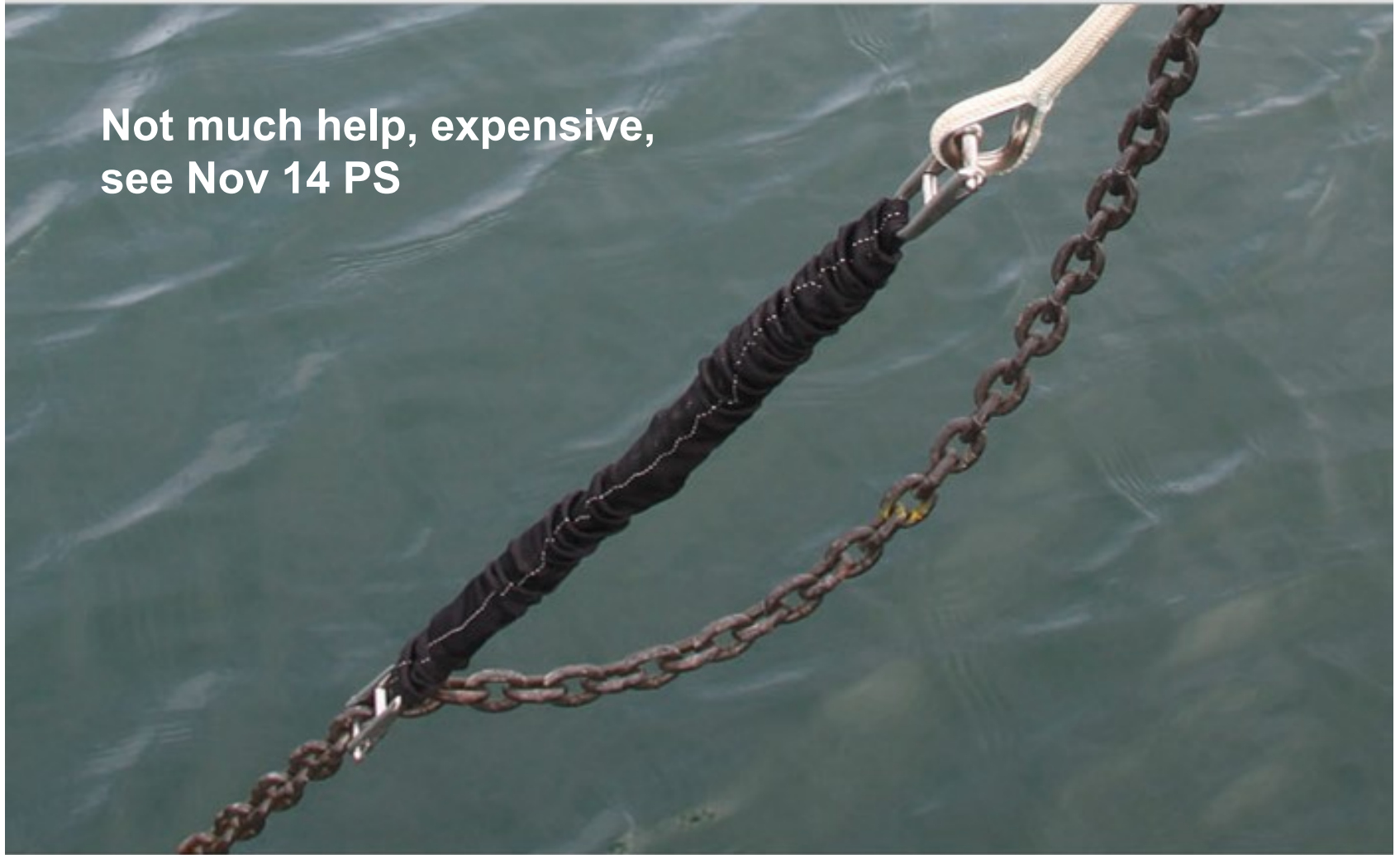

Soggy Paws Monohull Snubbers

- **Light working** – 10' x 5/8" single polyester w/ SS chain hook
 - for setting anchor and light conditions
 - Normally attach to chain just above water to keep line clean in dirty harbors
- **Heavy primary** - 35' x 3/4" doubled single braid nylon w/ Amsteel soft shackle
 - Rig on deck to two cleats to spread load
 - Runs over bow roller w/ chafe gear
 - Full strength of chain, easily adjustable to increase length for storms

Soggy Paws Catamaran Snubber

- Primary – Bridle of 35'x $\frac{3}{4}$ " nylon rigged to designed strong point at forward cross beam corners.
- For normal conditions reeved through smooth $\frac{5}{8}$ " SS shackle to on deck cleats so can be adjusted for depth.
- For storm conditions bitter ends with hard eyes shackled to cross beam corners.
- Backup rigged from strong point on deck of $\frac{3}{4}$ " nylon to chain hook in case bridle fails.

Why a Swivel?

- Allows rotation of BIG anchors to proper orientation for lifting over roller
- Helps prevent chain twist with grooved roller and during long term anchoring
- Must choose carefully and ensure full chain strength is preserved



Stainless Steel Swivels

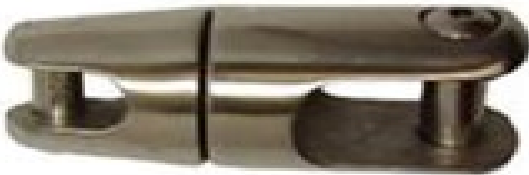
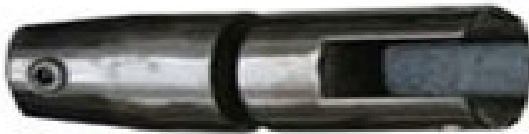

- **All** Must use with **shackle between anchor and swivel**
- Must have **full strength of chain**
- Evaluate design and pin size carefully
- **Best if can take apart** for full inspection annually
- If can't inspect all parts for problems is **bad design**

SS Swivel Testing

- Good information sources
- SS Swivel Fracture Analysis-
<https://www.fsc.com.au/wp-content/uploads/2016/07/Anchor20Swivel20Report.pdf>
- Anchor tip weights video SV Panope-
<https://www.youtube.com/watch?v=I59f-OjWoq0>

HDG Mild Steel Swivels - Jawed



HDG Mild Steel Swivels - Bail



SS Swivels - Power Ball

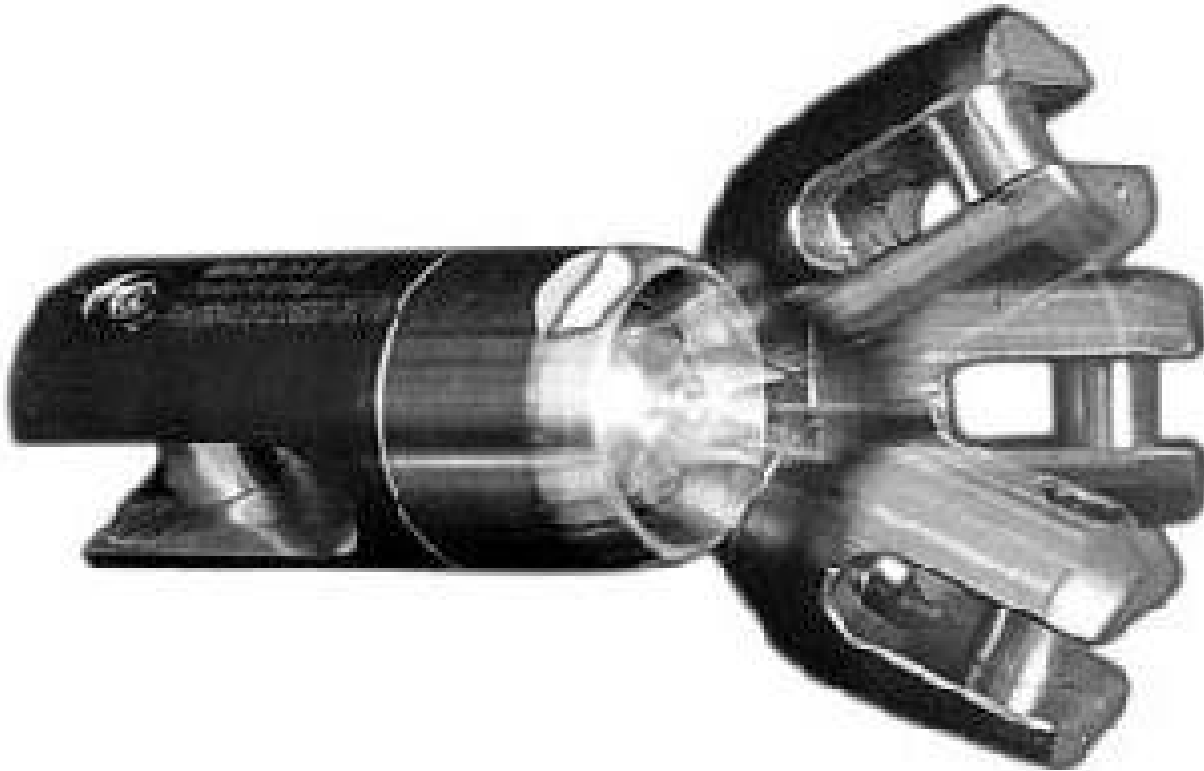

SS 3/8" SWL 3600#, BS 14,400#

SS Swivels - Anchorlift



SS 3/8-1/2" BS
15,400#

SS Swivels - Ultra

Auto rotates anchor at roller for retrieval
316L SS, 3/8" BS 18,800#

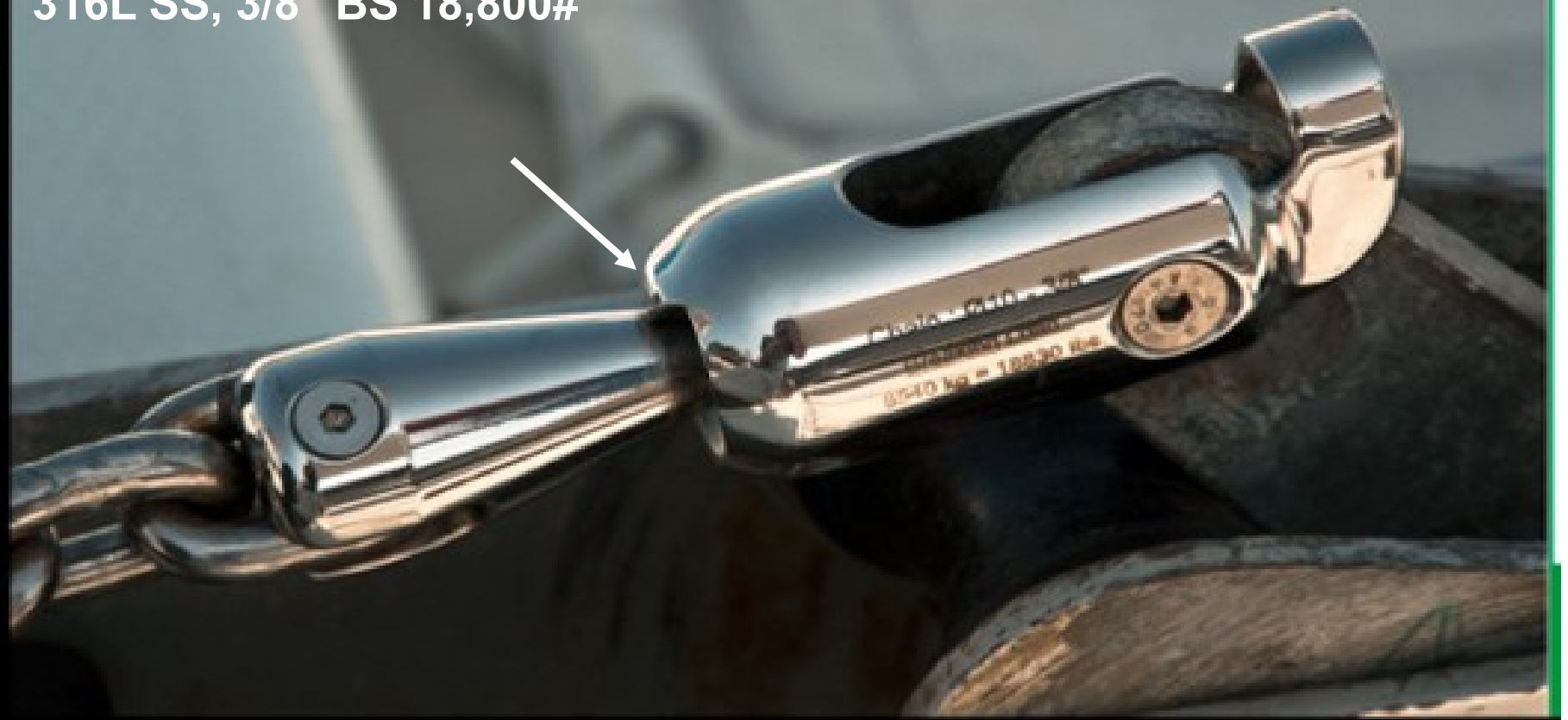

SS Swivels - Suncor



17-4 PH SS
3/8-1/2" BL 15,000#

SS Swivels - Italian Kong



**Can entirely disassemble
3/8" 316 SS, SWL 6600#**

Mantus Swivel

Chain PIN is oblong and made from 2507 Duplex Stainless Steel

Integrated shackle eliminates the risk of side loading the swivel

Shackle features a hex head, making it streamlined but still easy to safety wire

In my opinion this is best chain swivel featuring full HT chain strength, eliminating possibility of side loading and can be fully disassembled



Kong Swivel in Use



Bad Swivel Connections

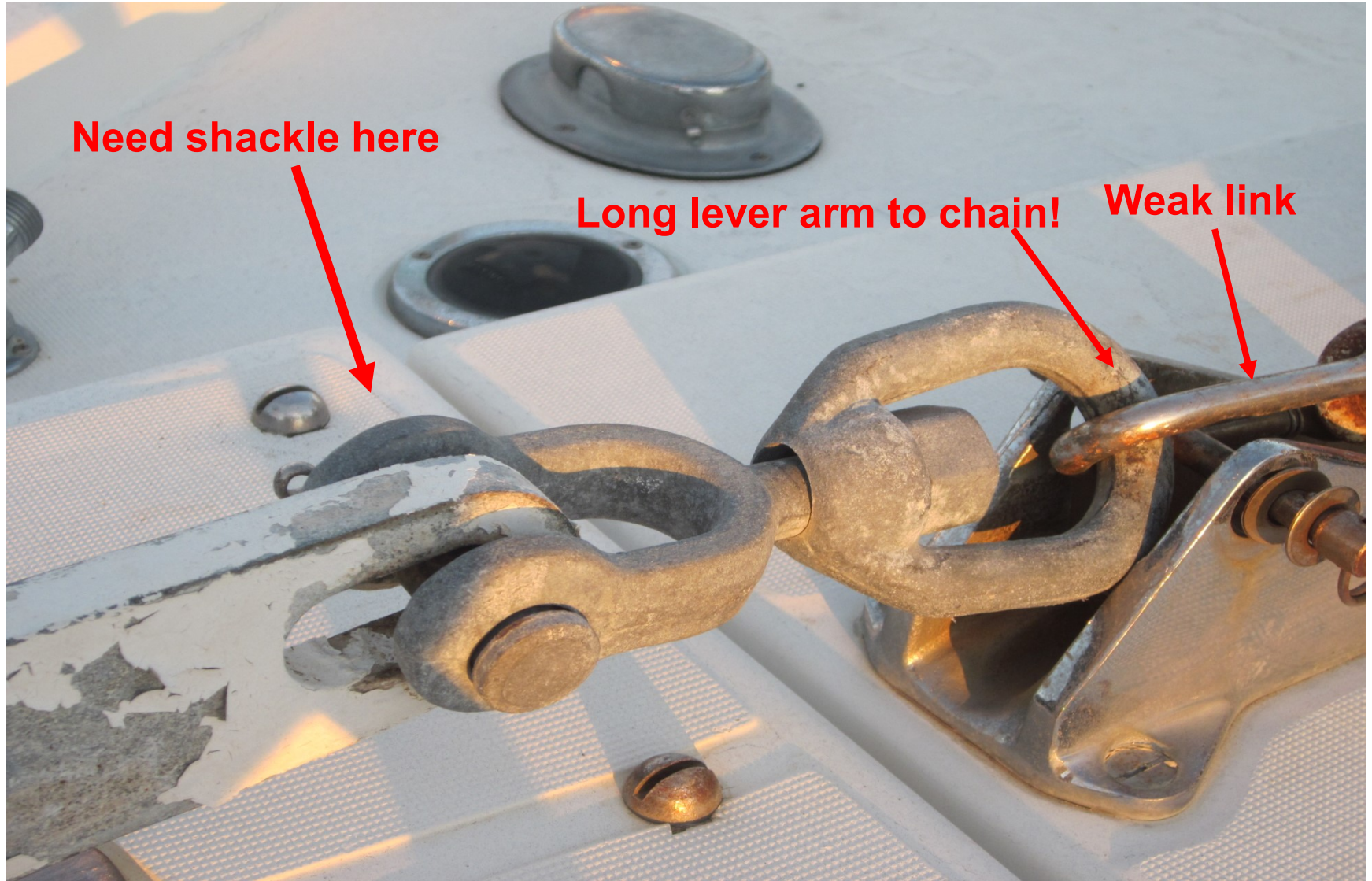

Bad Swivel Connections

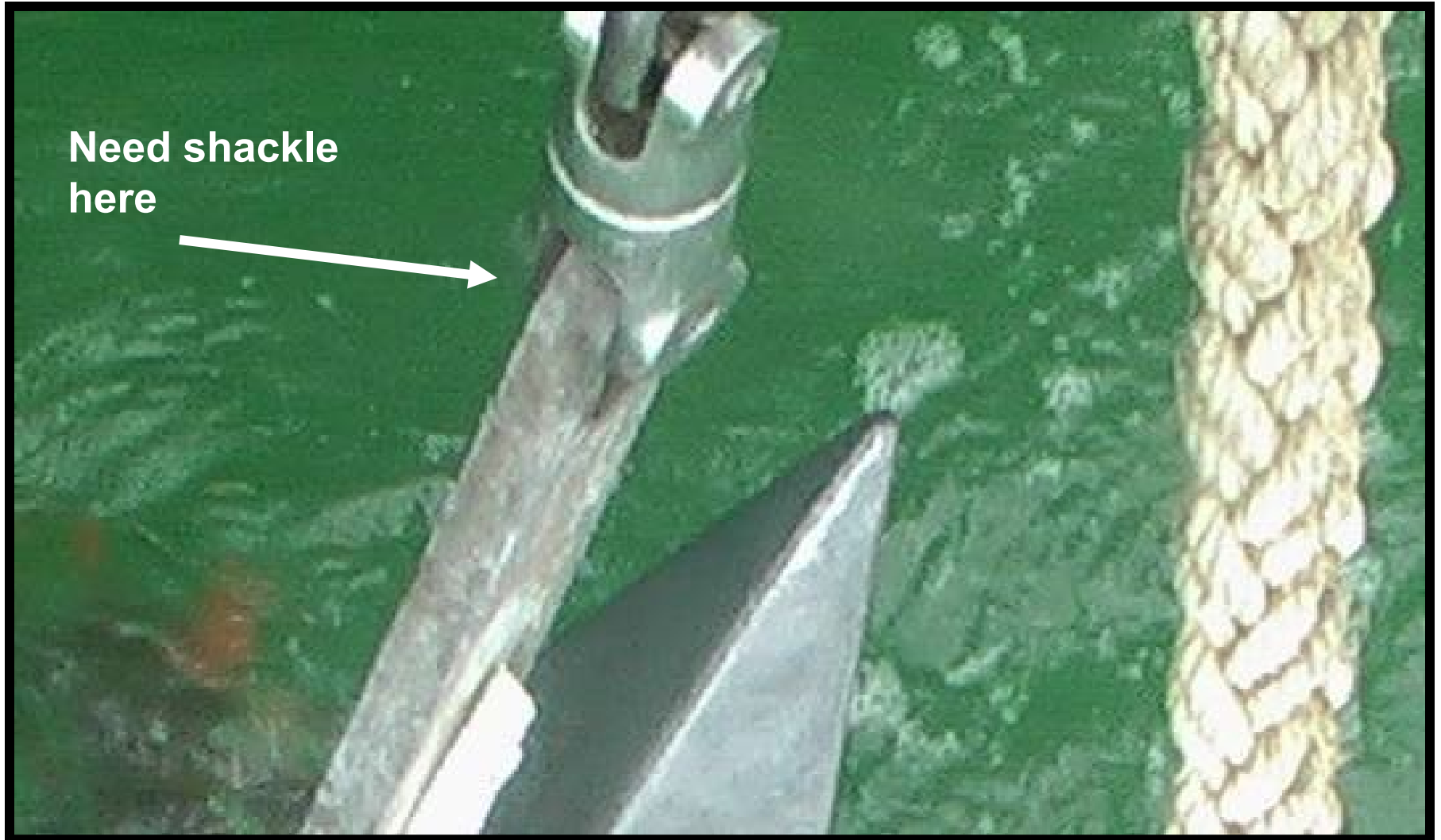

Proper Swivel Attachment

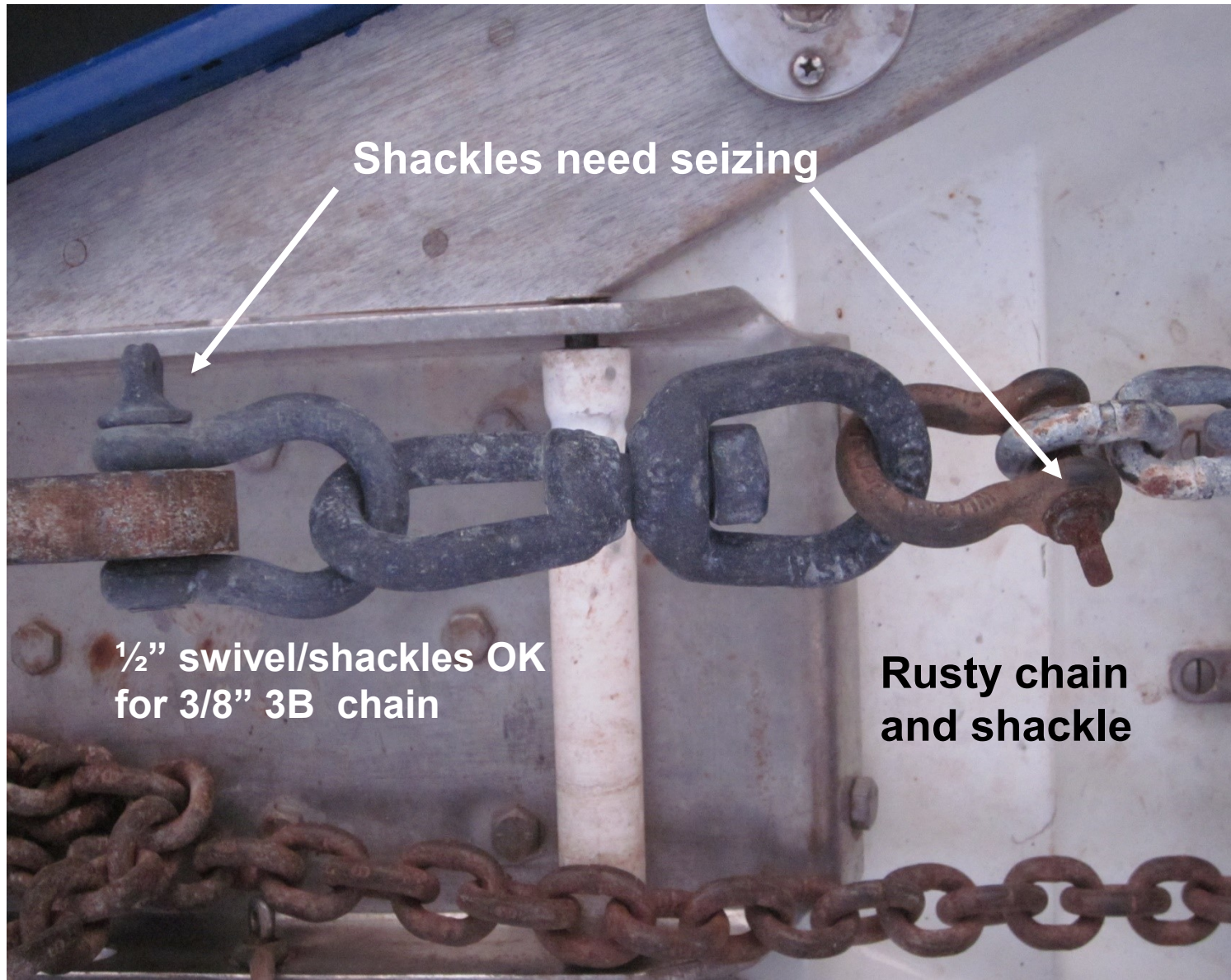

Shackles need seizing

1/2" swivel/shackles OK
for 3/8" 3B chain

Rusty chain
and shackle

Proper Swivel Attachment

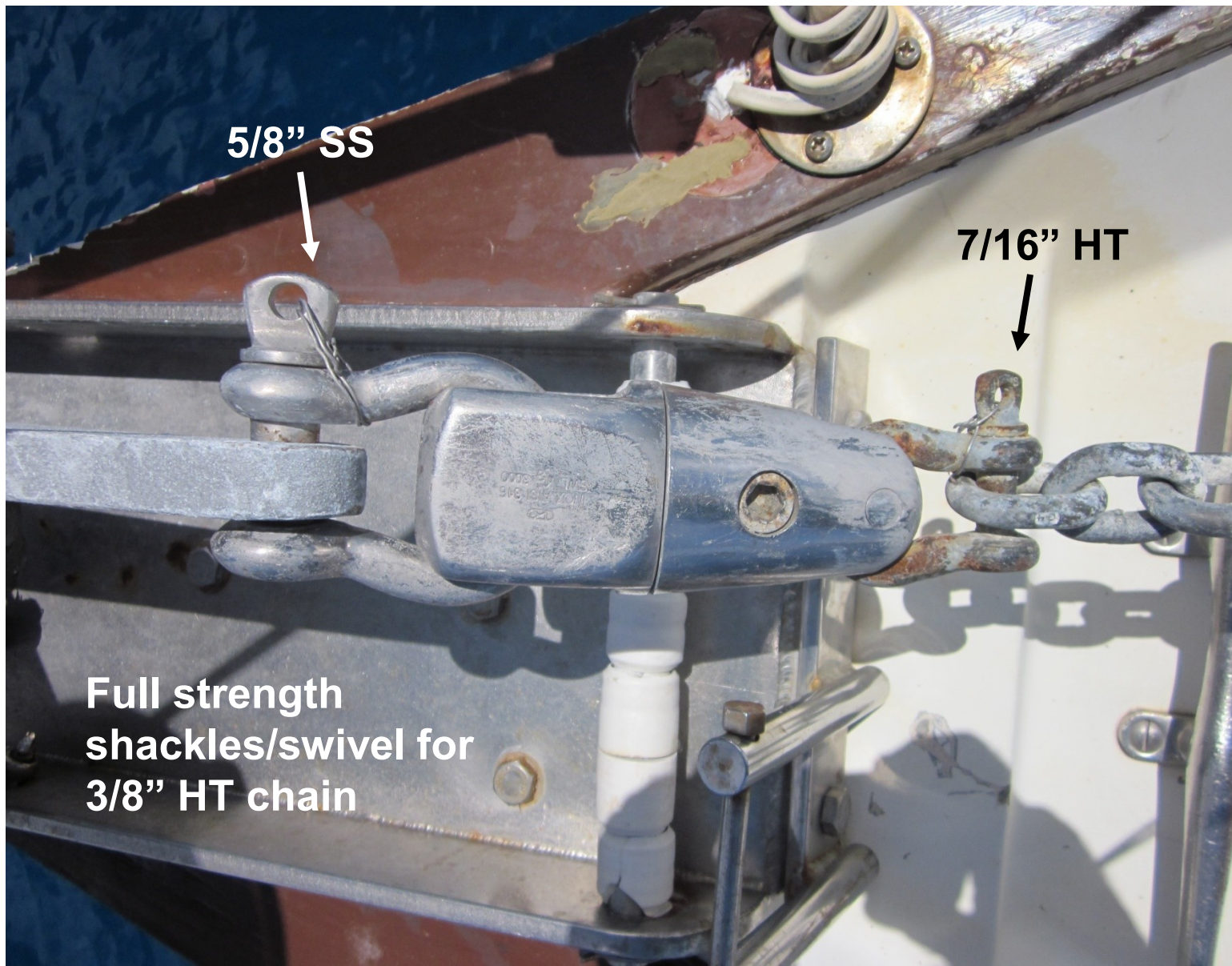

Anchor Rode Tray and Rollers

- **Strongly built, Stainless Steel best**
- **Aluminum** roller for chain
- **Delrin** roller for line
- **Groove in chain roller** prevents twisting
- No sharp edges on front of tray
- Tight fit roller sides to tray, delrin washers
- Smooth bail to keep rode on roller
- Hinged tray for big anchors

Delrin Roller for Line

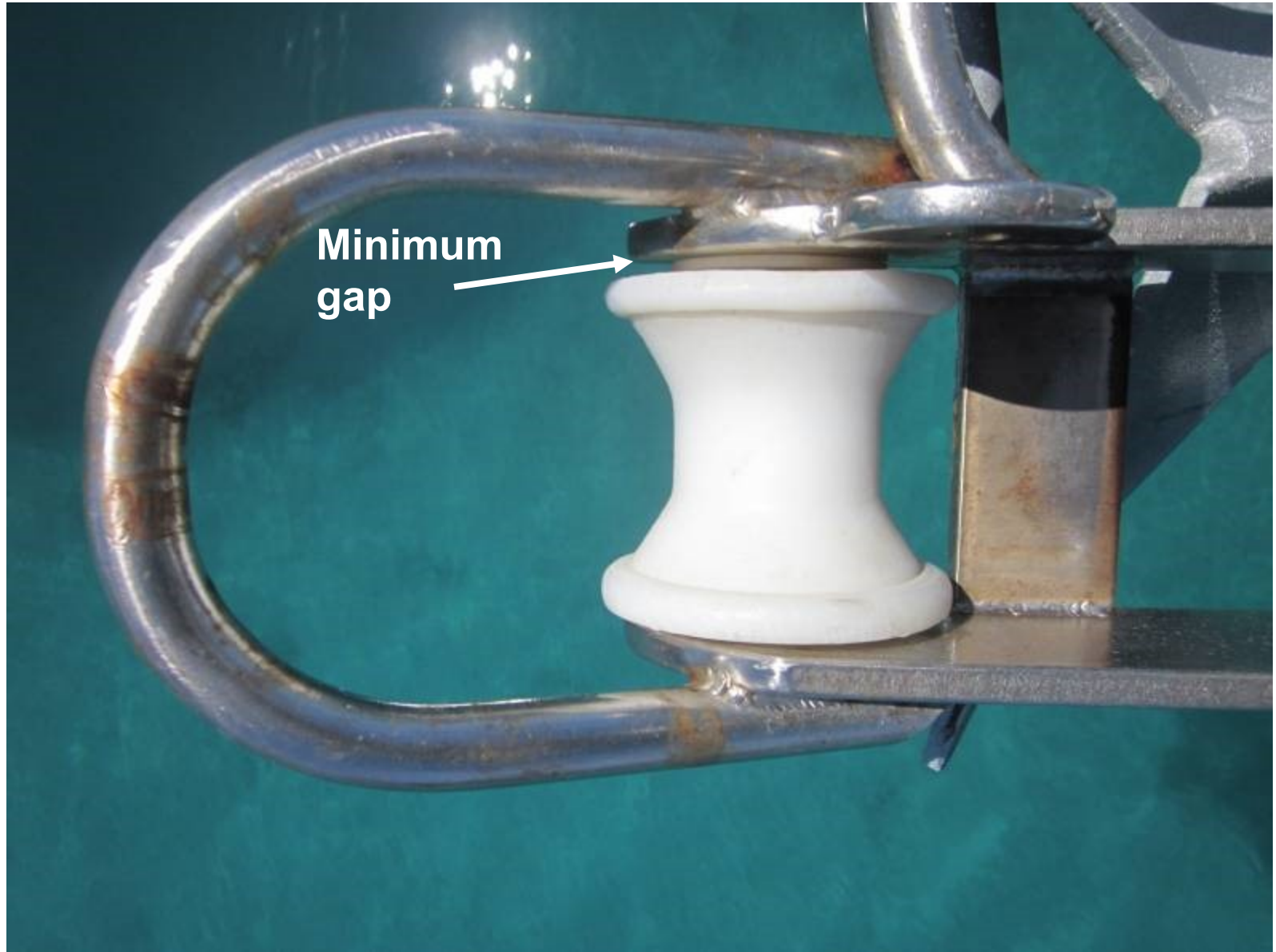

Aluminum Roller for Chain



Aluminum has same hardness as galvanizing & no UV deterioration

Groove in roller prevents twist

Twin Roller Trays Problems

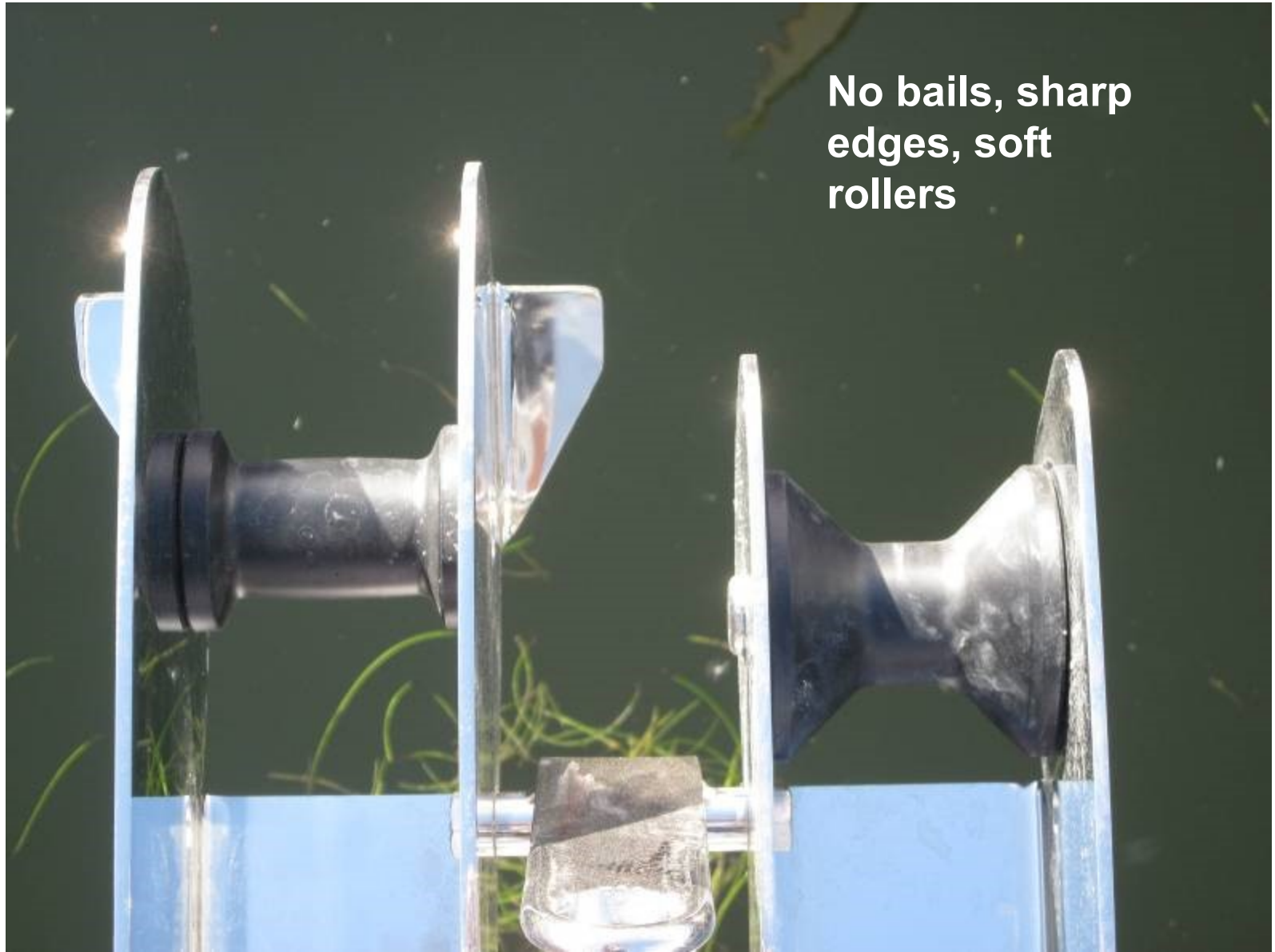

Proper Roller Tray Bail



Dual Roller Trays & Bails



Roller Tray w/ Removable Pin



Hinged Anchor Roller Tray Extension



Hinged Anchor Roller Tray Extension

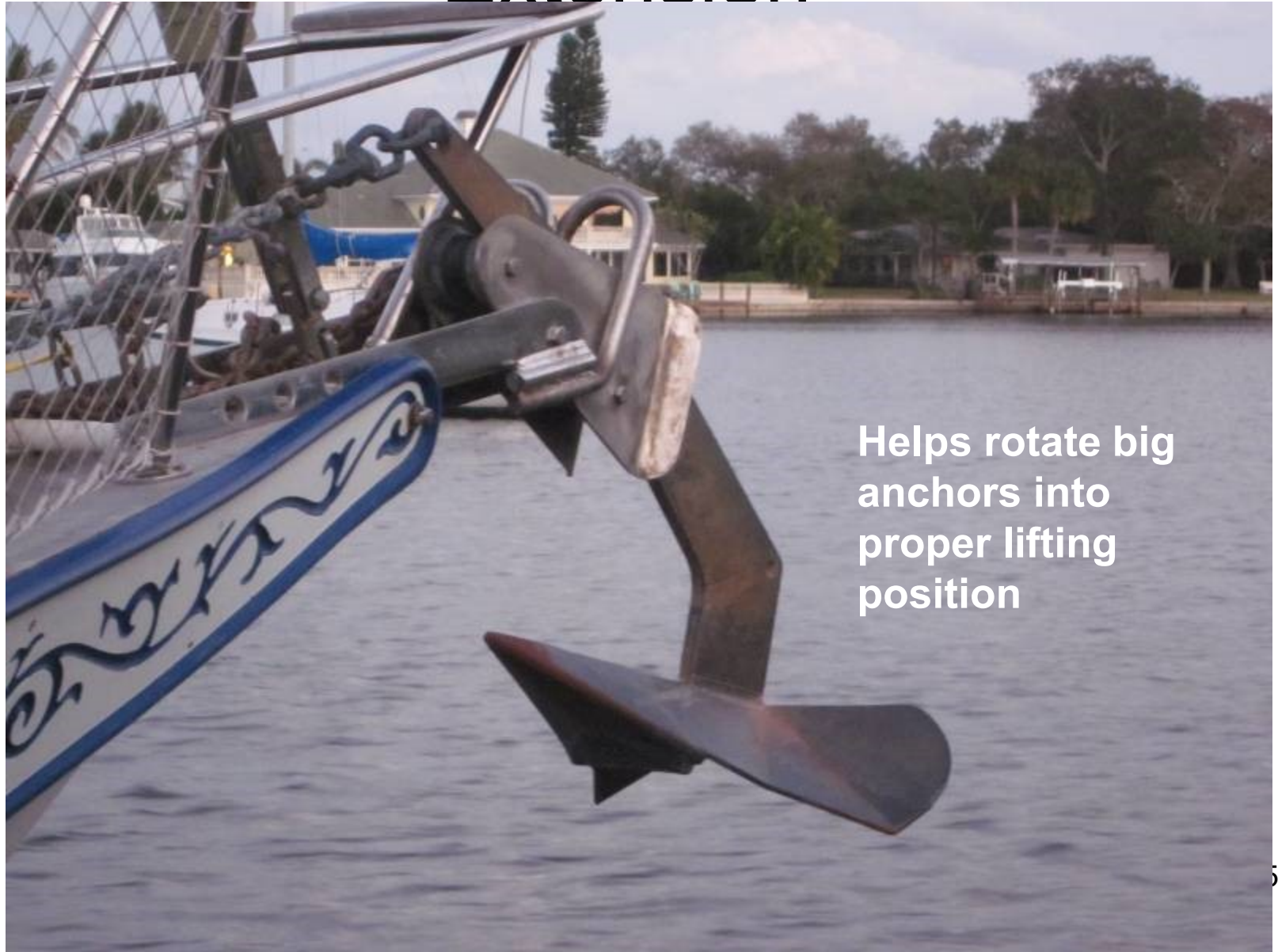

Helps rotate big
anchors into
proper lifting
position

Hinged Anchor Roller Tray Extension for Chain



Broken Anchor Rollers

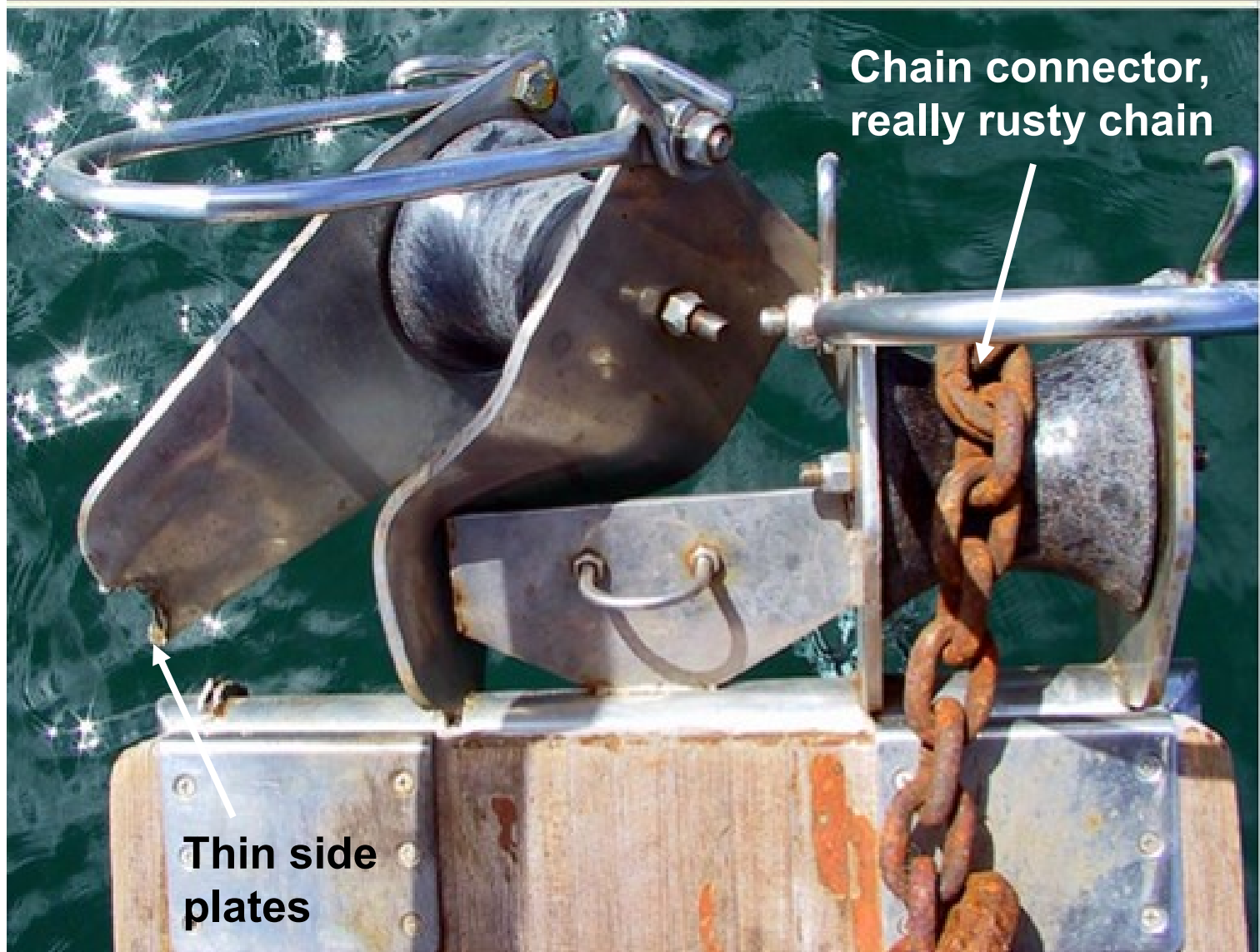

Q & A Ground Tackle



SOTRA ANCHOR & CHAIN has become known as the world's largest stockist of anchors and chains. The company have today more than 10 000 tonnes brand new and second hand anchors, chain, shackles and accessories for supply within shipping, offshore, aquaculture, shipyards and even to decoration market.

ANCHORS



Which of these 14 anchors fared best in simulated For

Basic Anchor Types

- **1G Hook** – Admiralty, Luke, Herreshoff, etc.
- **1G Rotating Fluke** - Danforth, West, Fortress, copies
- **2G Claw** – Bruce, Ray, Max, copies
- **2G Plow** – fixed Delta; hinged CQR, copies
- **3G Scoop** –
 - w/o rollbar- Spade, Ultra, Vulcan
 - w/roll bar- Bugel, Rocna, Manson Supreme, Mantus
- **Misc** –Bulwagga, Barnacle, Hydrobubble, etc, etc, most no longer produced

Rotating Fluke Anchor Terms

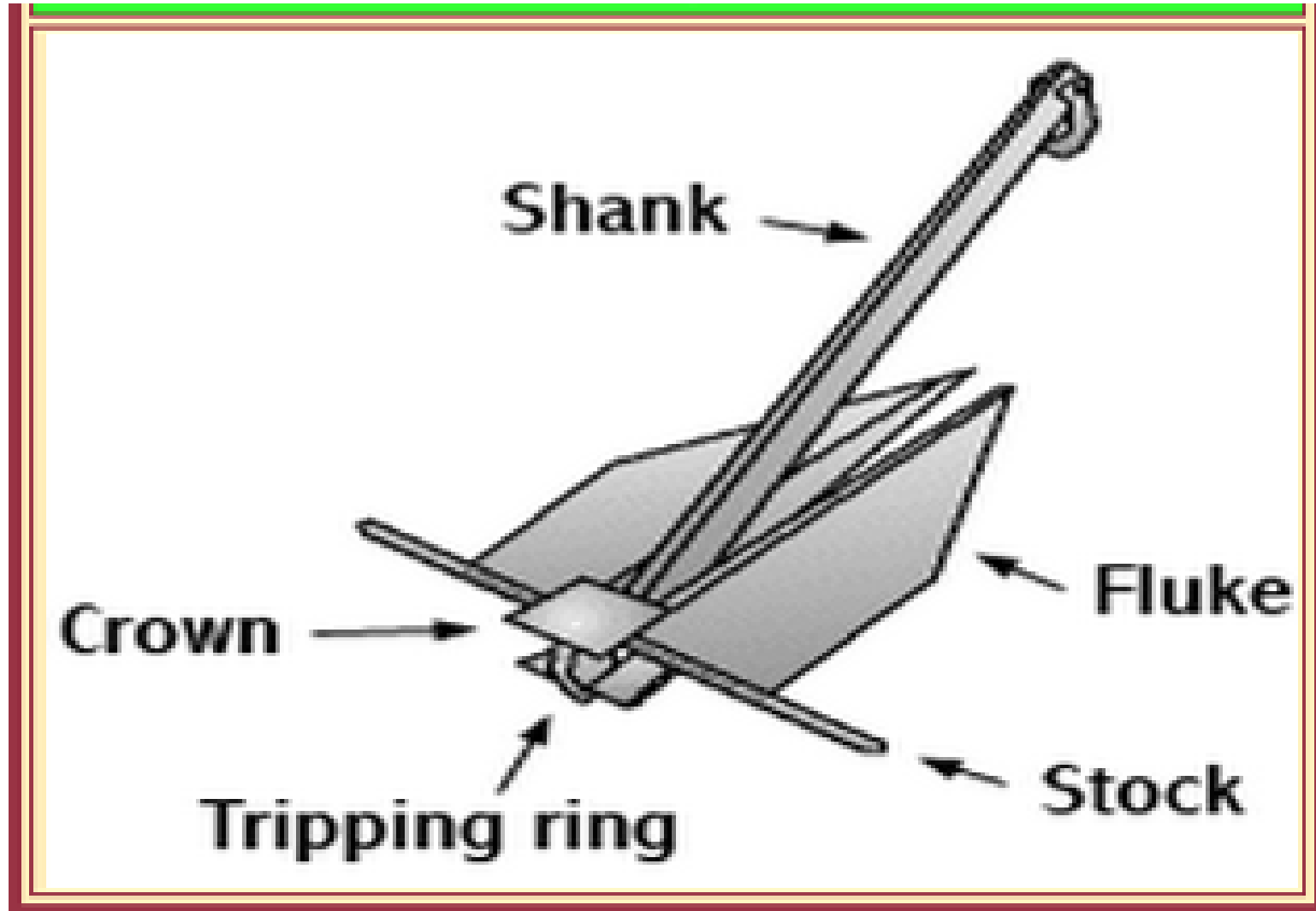



Modern Generation Scoop (MGS) & Plow Terms

Plow vs Scoop Anchors



**Older
Generation
Plow**

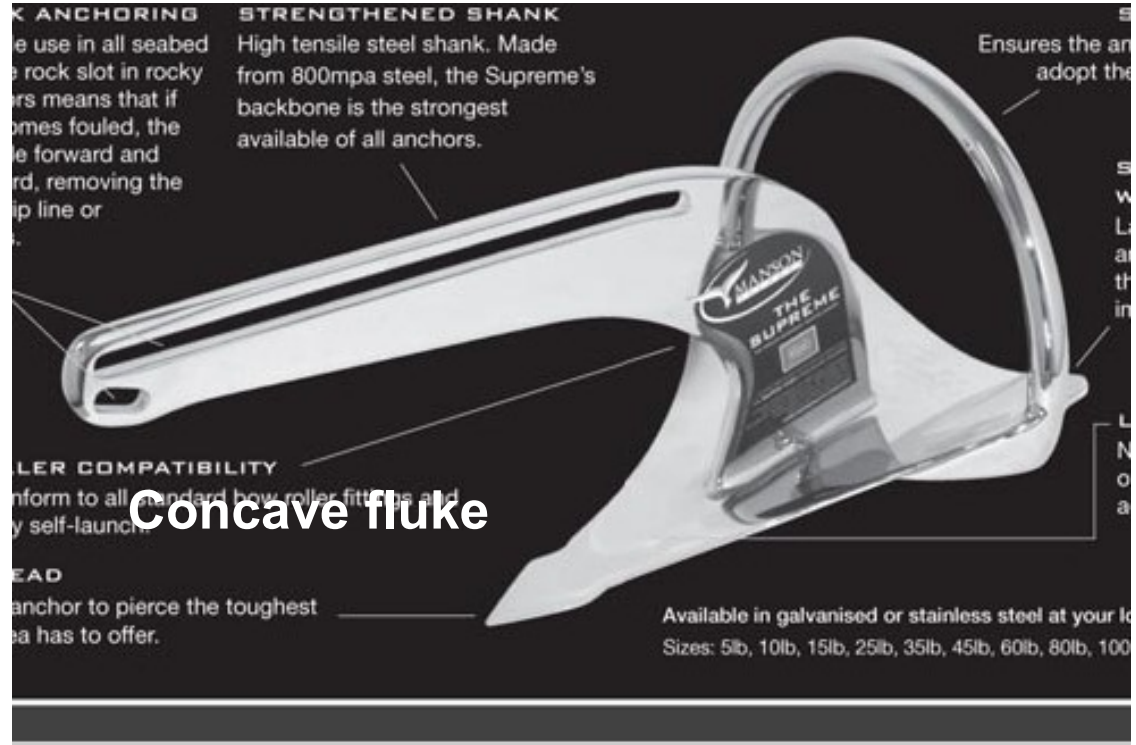

Concave fluke

**Modern Generation
Scoop**

Ideal Characteristics of Primary Anchors

- **High relative holding power** – (SHHP) rating
- **Holds well** in wide range of sea beds
- **Superior resetting** ability – turns with wind & tide w/o pulling free of bottom
- **Stable when dragging** and won't pull out of bottom
- **High strength** design and material, HT shank
- Assumes **correct bottom position** for rapid setting
- Convenient stowing, easy launching ability

Holding Definitions

- **Ultimate Holding Capacity**, UHC, the maximum load which a fully buried anchor can withstand without moving in the sea bed.
- **Dynamic Holding Force**, DHF, maximum load dragging anchor can withstand. **Greater than UHC** and increases with drag speed. Stability remaining in bottom key attribute.
- **Efficiency** = $\text{UHC} / \text{anchor weight}$
 - Allows holding comparison of multiple types of anchors of dissimilar weights.
 - Heavier anchors have greater fluke size and should have greater efficiency.

Holding & Resetting Characteristics

- **Positives:**
 - Flat/Scoop much better than Plow due to differences in way they hold (sheer vs slide in soil).
 - Increased physical size means greater fluke surface area
 - Increased weight.
 - Ability to dig deeply into higher holding capacity soils.
 - Sharp chisel shaped or down turned tip.
- **Negatives:**
 - Anything that resists penetration depth, ie wide shank, high weight, wide tip front, roll bar, short catenary, etc.
 - Reduced size, fluke area or weight.
 - Incorrect shank angle

Construction Strength

- Strength of metal important but not the whole story.
 - Also must consider thickness, geometry, lever arm, weld quality, etc.
 - Better design and welding, but weaker metal, may still mean a stronger anchor.
- Which shank shape is stronger (assuming equal metal cross section of vertical sides and strength of metal, not space inside)?

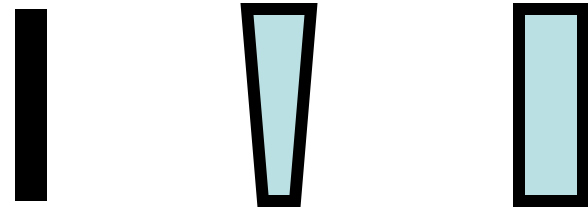

Box shape is strongest due to wider horizontal webs but wider shank impedes penetration

Shank Construction Strengths

	Material	Ultimate/Yield
Danforth HT	HT Fe Shank	81/52K
Fortress *	All 6061-T6 Alum	45/40K
Bruce *	All Forged Fe	120/91K
CQR	Forged Fe Shank	120/91K
Delta *	All Manganese Fe	136/51K
Rocna/Vulcan	HT Fe Shank	Proprietary
Manson Supreme	HT B80 Fe Shank	120/109K
Spade	HS G50 Fe Shank	65/55K
Ultra *	All 316L SS	70/25K
Mantus	HT A514 Fe Shank	110/100 ₇₁

Early Age of Discovery Galleon Anchor



1622 Spanish
'Atocha' Galleon
Anchor

Basic Concrete Block Anchor

(cheap & very popular with third world locals!)



Primary **Cruising** Anchors Types

- **Plows**- CQR, Delta and their copies
- **Claws** – Bruce and its copies
- **New Generation Scoops** – Spade, Rocna, Manson Supreme, Ultra, Manta, Vulcan
- **Others** – Max, Bulwagga, Barnacle, Hydrobubble

Considerations before Buying

- ‘No anchor is as good as the maker claims or as bad as the competition claims’.
- ‘When it comes to anchors, bigger and stronger are always better, but better design is much better’.
- ‘Luster and higher cost does not necessarily mean you bought a better anchor’.
- ‘No such thing as the perfect anchor’.
- ‘Research, research, research’.

Old vs New Generation Anchors

- “Older generation anchors are no better or worse than they have ever been, but now we have better technology” - Well known SSCA member.
- “Superior resetting ability is critical, especially at 3 AM when the crew is asleep” – Sleepy crew.
- “Many sailors are traditionalists and traditions resist change”. Alain Poiraud – Spade
- “Plow anchors are designed to plow not dig a hole” – Local farmer plowing field w/ CQR.

Hinged Plows - Simpson Lawrence CQR Anchor 1933

Some forged HT steel shanks

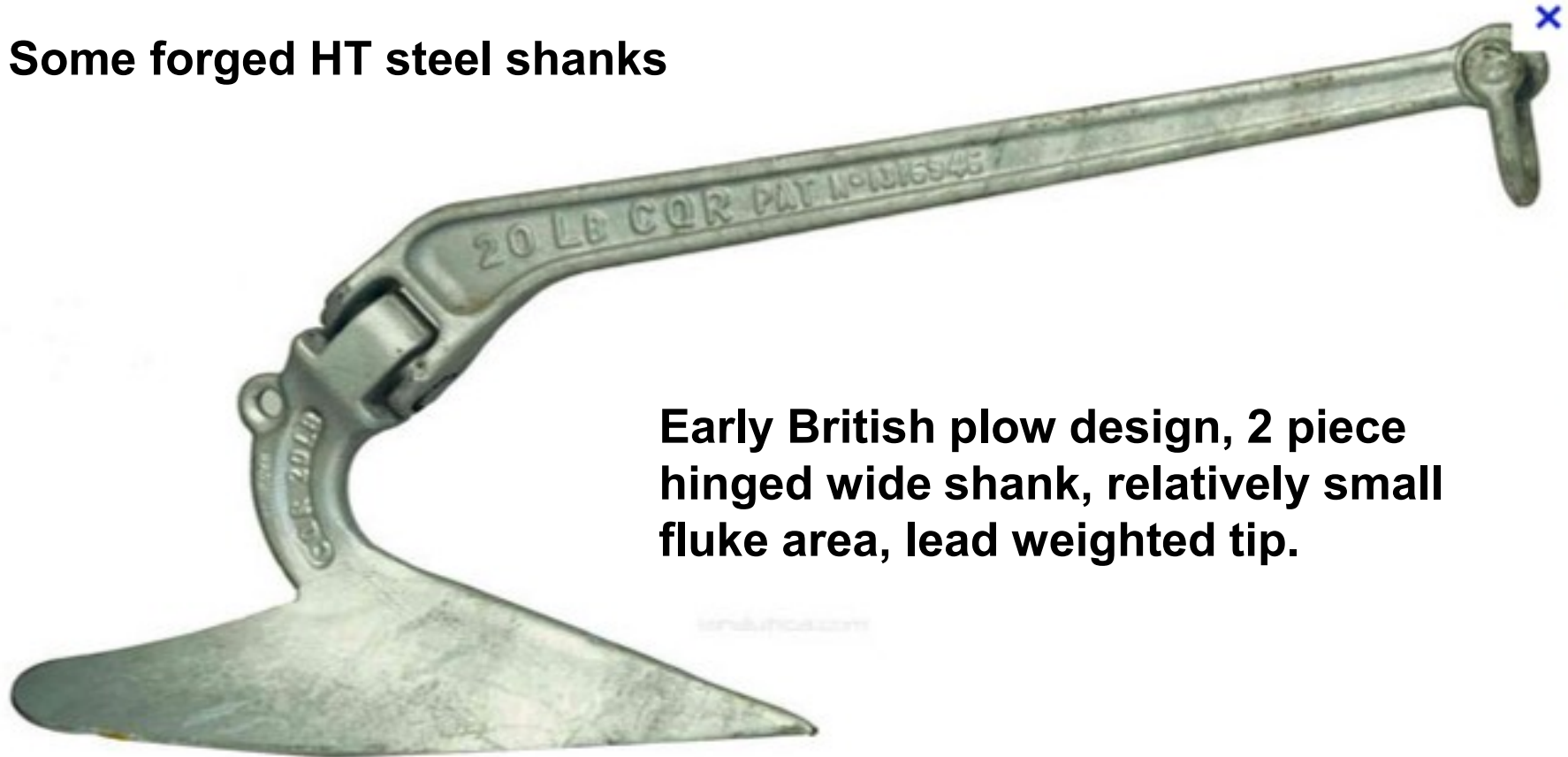

Early British plow design, 2 piece hinged wide shank, relatively small fluke area, lead weighted tip.

CQR Characteristics

- Most holding tests show about **35% of holding power of modern scoop** anchors.
- **West Tests 2006** - 'Consistently failed to set at 5 or 7:1 scope'. Max brief load 2000 lbs. Dug considerable trench on beach test
- **PBO 2011 Tests – Unstable serpentine motion when dragging. 47 lb efficiency = 8. Rating – Poor.**
- Small relative fluke area hinders holding capacity.

CQR Problems

- High knuckle and shank weight force anchor to lie on its side and impede setting, also wide shank.
- **Inconsistent setting performance**, sometimes not at all, poor holding in soft bottoms, failure to penetrate in harder bottoms.
- Does not tolerate weed/grass well.
- **Few redeeming features, other than good strength, compared to modern scoops.**

UHC Load Testing, CQR vs Rocna

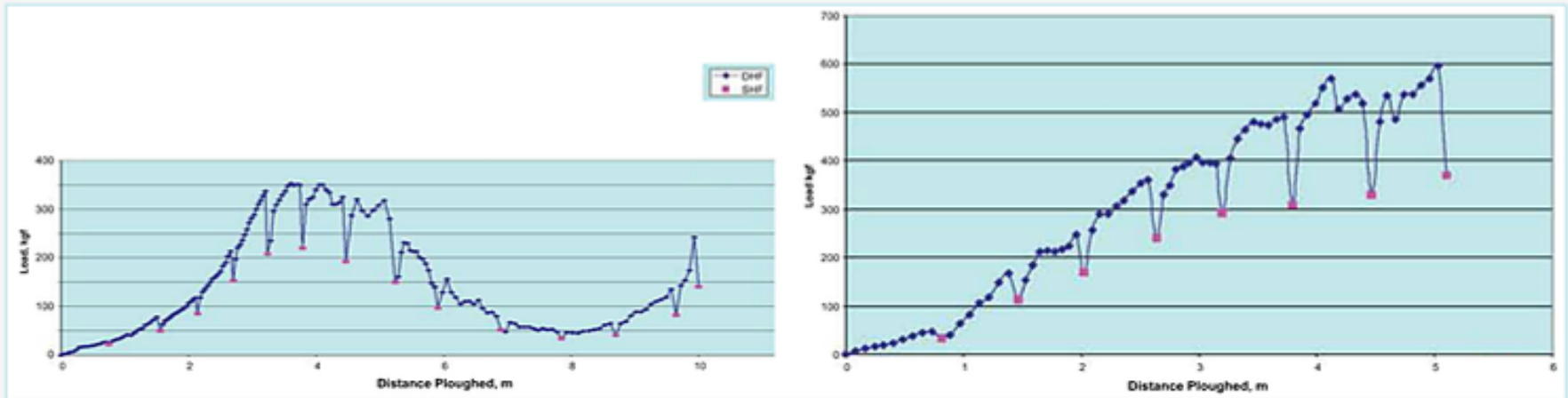

Load graphs for CQR (left) and Rocna (right) anchors. The dipped points in pink track the SHF for each anchor: the 45 lb (~20 kg) CQR snakes and rolls unstably, never exceeding a normalized SHF of 175 kgf, while the smaller Rocna 15 (33 lb) sets and buries quickly as its SHF climbs inexorably toward a normalized SHF of about 480 kgf. Graphs © Practical Boat Owner 2011

**Other hinged plows vs modern scoops produce similar results.
Testing done by Dr John Knox in 2011**

Manson Plow 1972

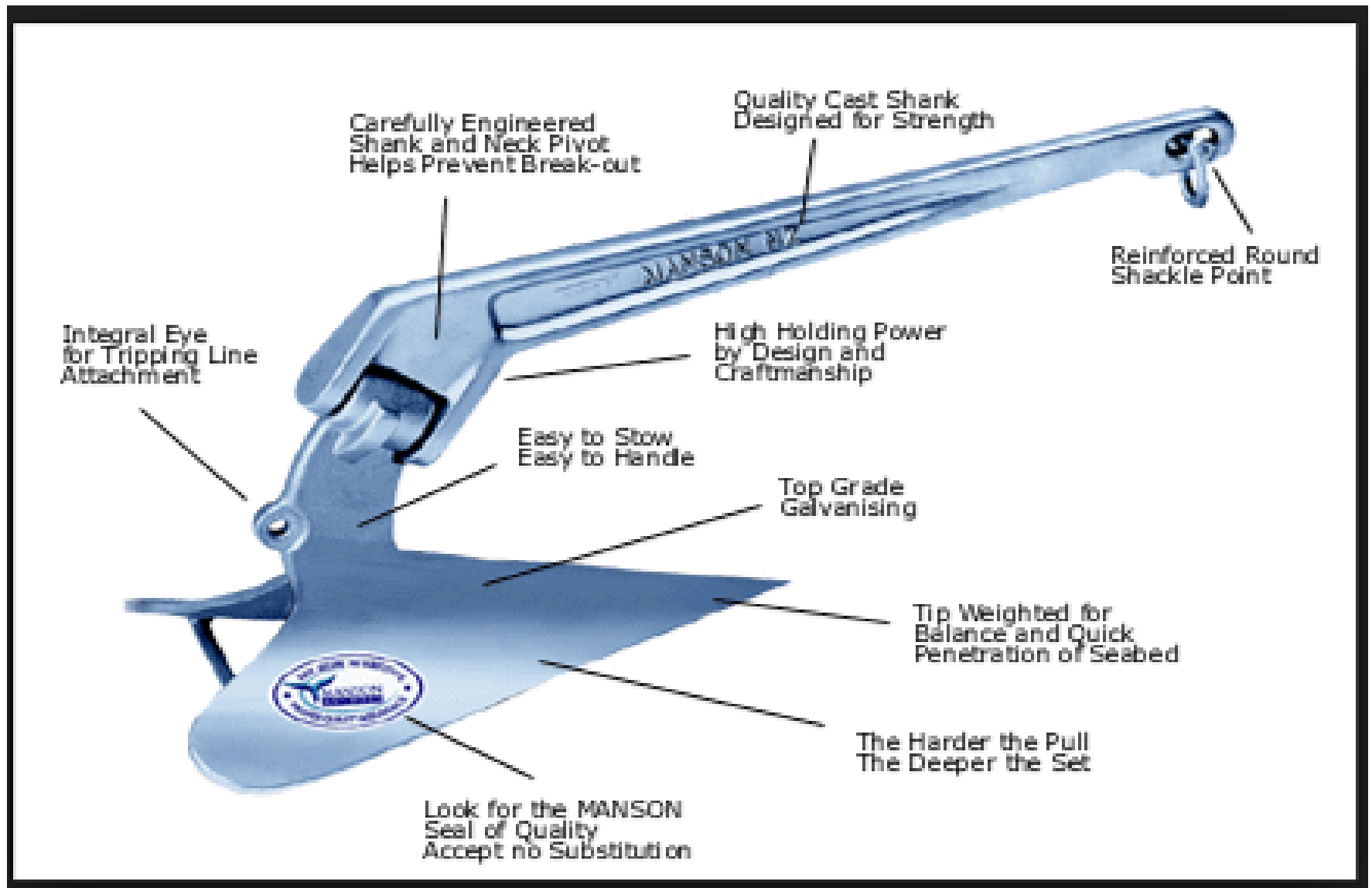

Manson Stainless Steel Plow



Norestar Plow



Norestar

China Hi Sea SS CQR Copy



<http://www.chinahiasea.com>

Claws - Bruce Anchor 1971



A genuine 50 KG Bruce -
No longer produced

Strong forged one piece
construction, triple flukes
with small blade area

Bruce/Claw Characteristics

- Most holding tests show about **30% of holding power of modern scoop** anchors.
- **West Tests 2006** - 'During most pulls it set and released rapidly with **max brief load of 885 lbs**'.
- **PBO 2011 Tests** – Stable when dragging, but at low loads. **36 lb efficiency = 5. Rating – Poor.**
- **Fouling can be a problem** as triple fluke design traps rocks, coral and other undersea obstacles.
- **Extremely strong forged construction, best in rock/coral and kelp.**

Bruce/Claw Problems

- Three separate flukes, all fairly blunt, **do not penetrate weed/grass mat or harder bottoms very well.**
- Does not set particularly well in harder sea beds if the anchor lands upside-down.
- **Well known cruisers**, Dashews and Starzinger/Leonard, previously used Bruce anchors, now using modern Scoops.
- **Suffers from small fluke area.**
- Fouling with coral boulders and rocks

Lewmar Claw Anchor

High Tensile Steel

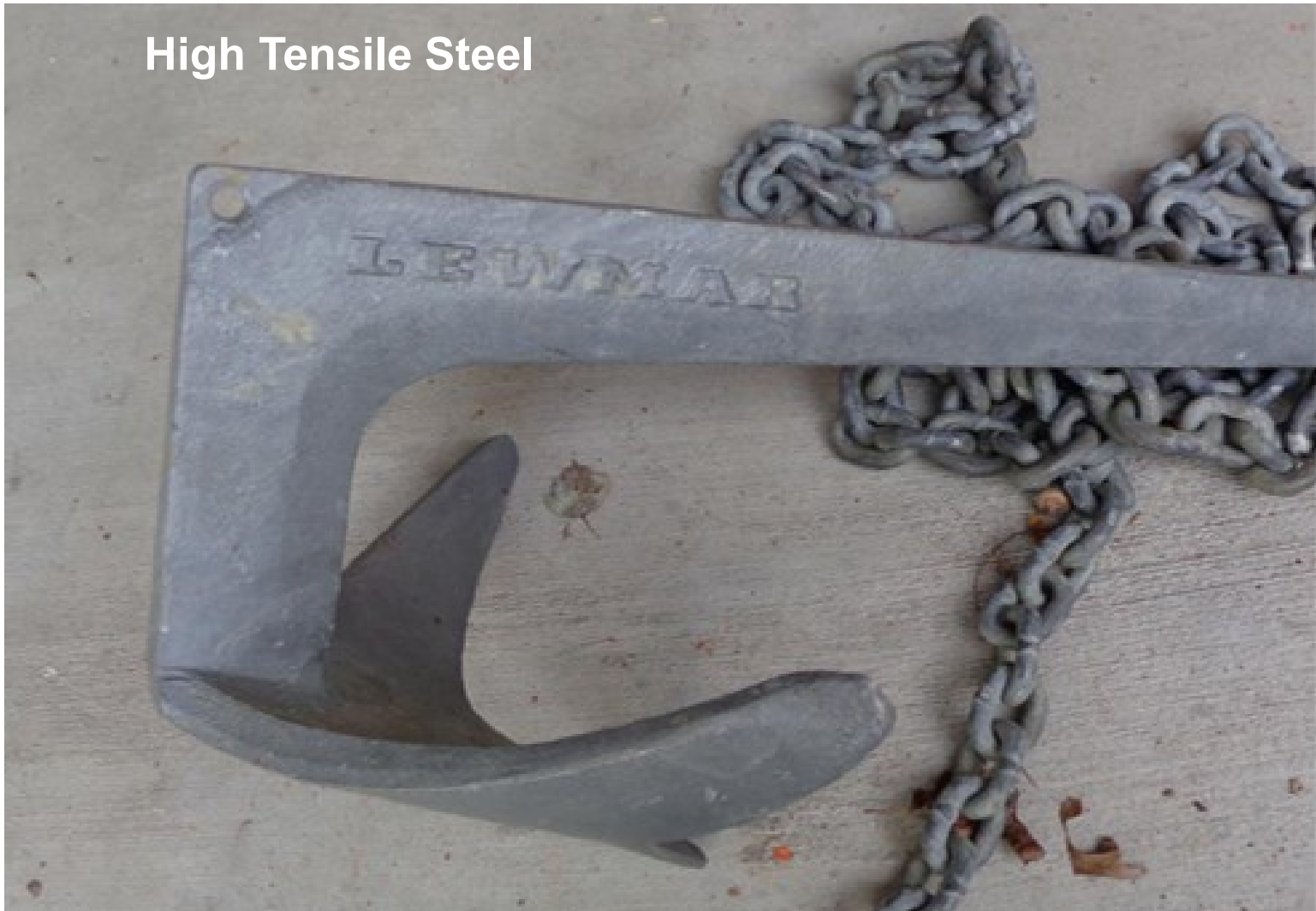

North Star Claw Anchor



Norestar SS Claw Anchor

Norestar



Manson Ray Claw Anchor



Forged Bruce copy

Plastimo Manta Claw Anchor



Plows - Delta Anchor 1990

Last of old generation plow anchors



- One piece plow design. Shank, and cast toe are welded to the fluke ridge.

Delta Details

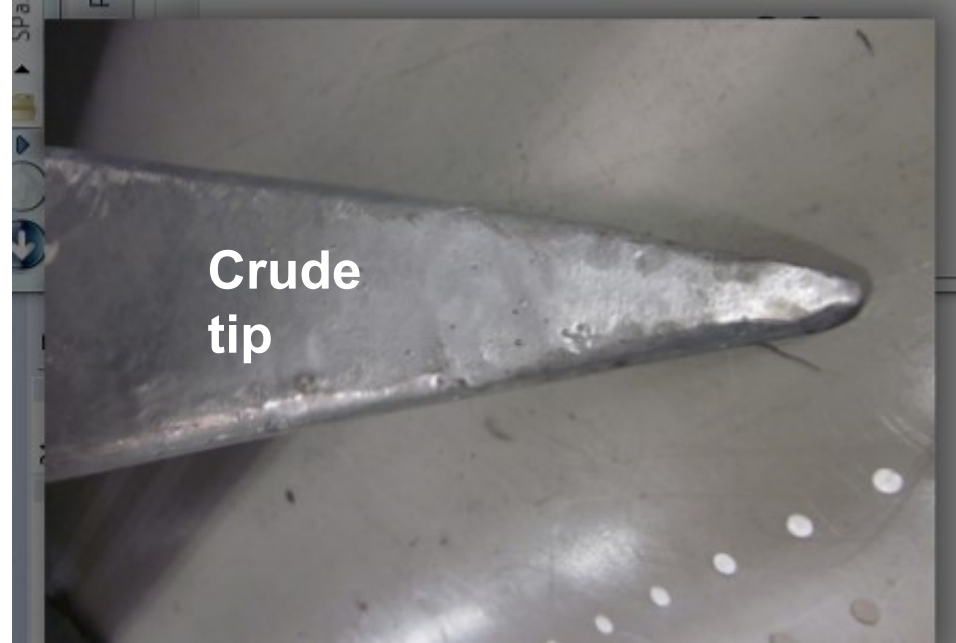
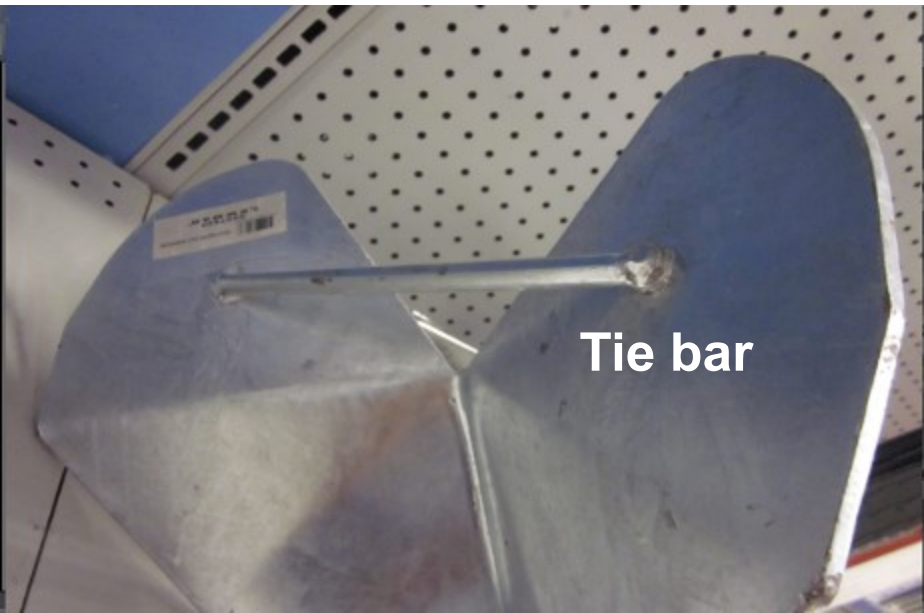
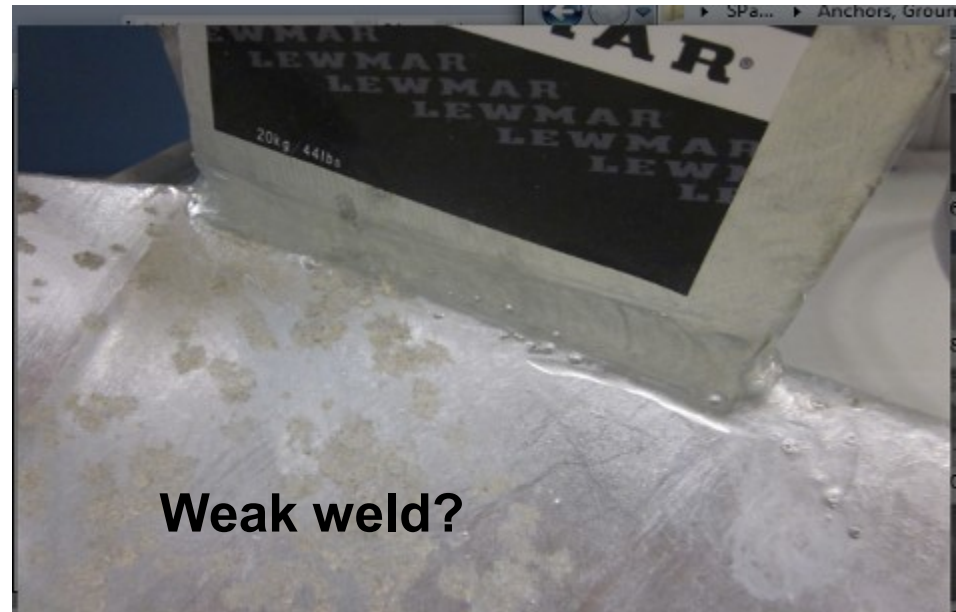

Delta Characteristics

- Most holding tests show about **half the holding power of modern scoop** anchors.
- **West 2006 Tests** – ‘Variable results ranging from 5000 to 3500 lbs. Results fell off at 3:1 scope and hard bottom.’
- **PBO 2011 Tests - Unstable when dragging. 36 lb efficiency = 11. Rating – Good.**
- In **soft mud holds weakly** due to plow shape and low efficiency
- About **two thirds price** of Modern Scoops so could buy a bigger stronger anchor for better holding.

Delta Problems

- **Some difficulty setting in weed/grass and very hard compact sand** due to plow design and relatively blunt tip.
- May release from difficult bottoms during severe wind veer/reversal **and not reset if drug rapidly.**
- **In soft mud difficult to set due to being stable upside down! If lands upside down will never set.**

Delta Anchor



**Soggy Paws
88# Delta**

Seachoice Plow Anchor



Excel Plow Anchor

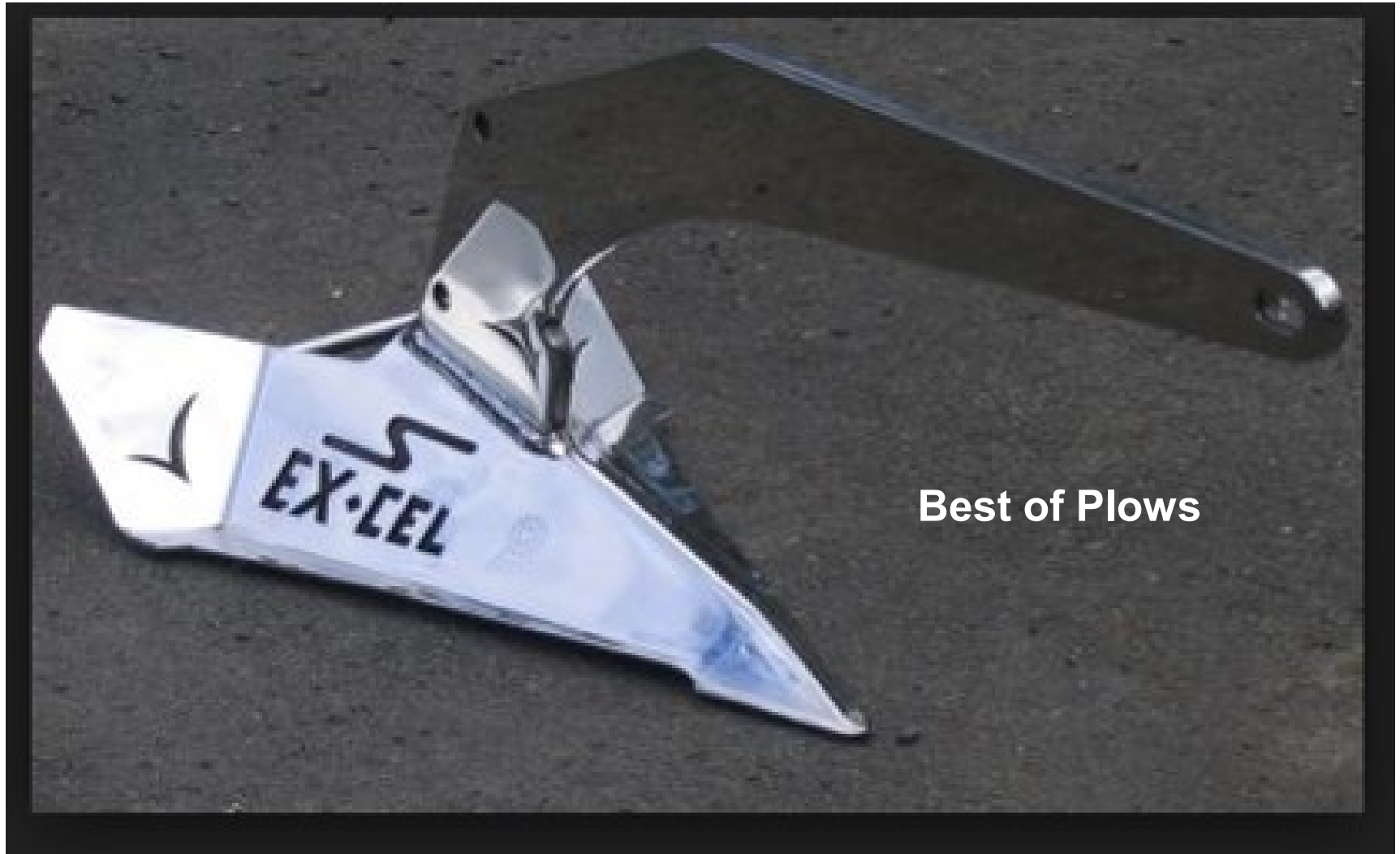

Best of Plows

Modern Generation Scoops - Bugel/Wasi Anchor 1986

**First of modern generation
anchors**



- **Somewhat primitive design with straight angled bar shank, relatively small flat pointed fluke, and big roll bar.**

Bugel/Wasi Characteristics

- German developed, **first of the modern generation anchors with a roll bar.**
- **About 2/3 holding power of modern Scoops** due to flat, relatively small blade.
- **Was popular in Europe** when first produced.
- **Many copies due to relatively simple design.**
- Little known and expensive in the US.
- SS or hot dipped galvanized.

Bugel



Spade Spoon Copy



Spoon

Spade Anchor 1996



French design, first true MGS, concave triangle fluke, heavily lead weighted sharp tip, removable high strength hollow shank

Spade Anchor

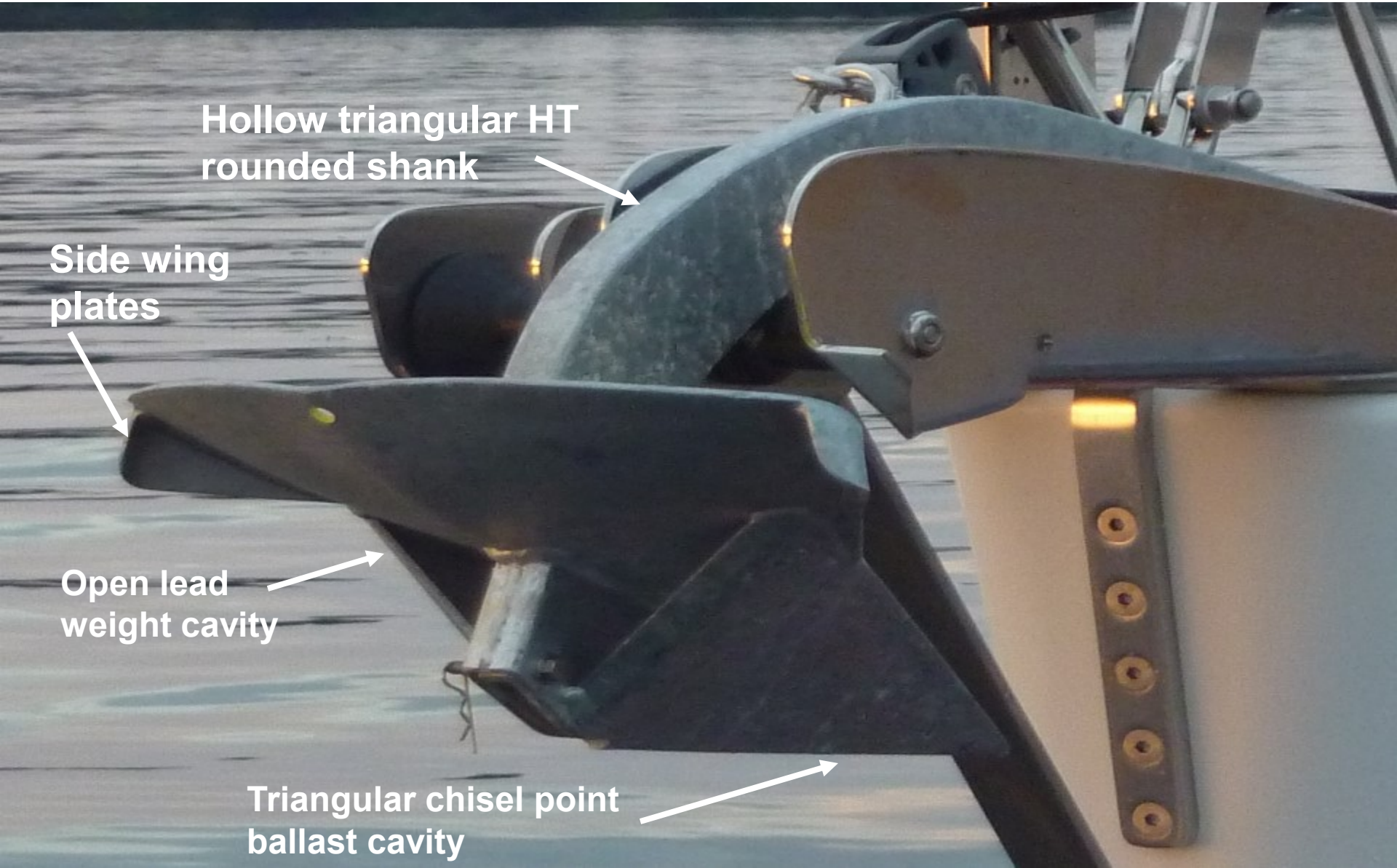

Hollow triangular HT rounded shank



Side wing plates

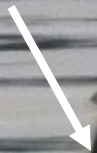

Open lead weight cavity



Triangular chisel point ballast cavity



Spade Anchor

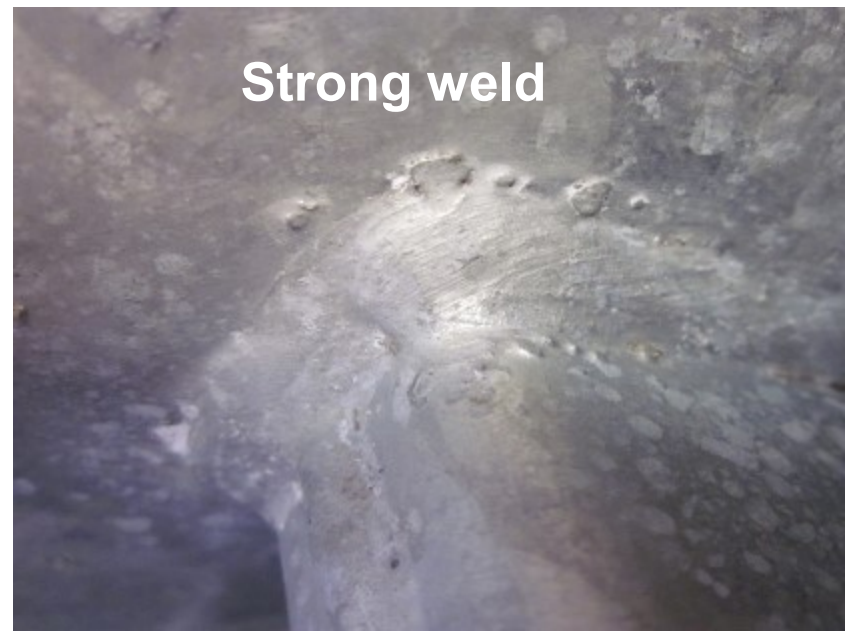
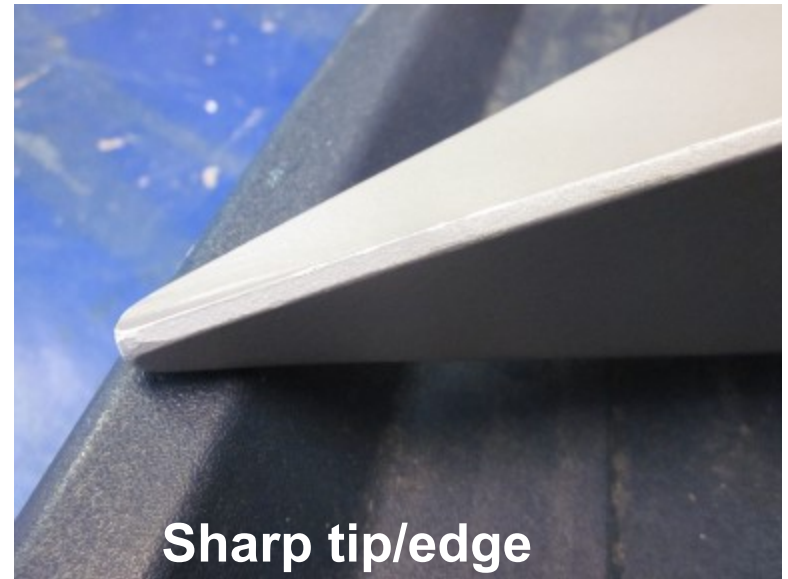
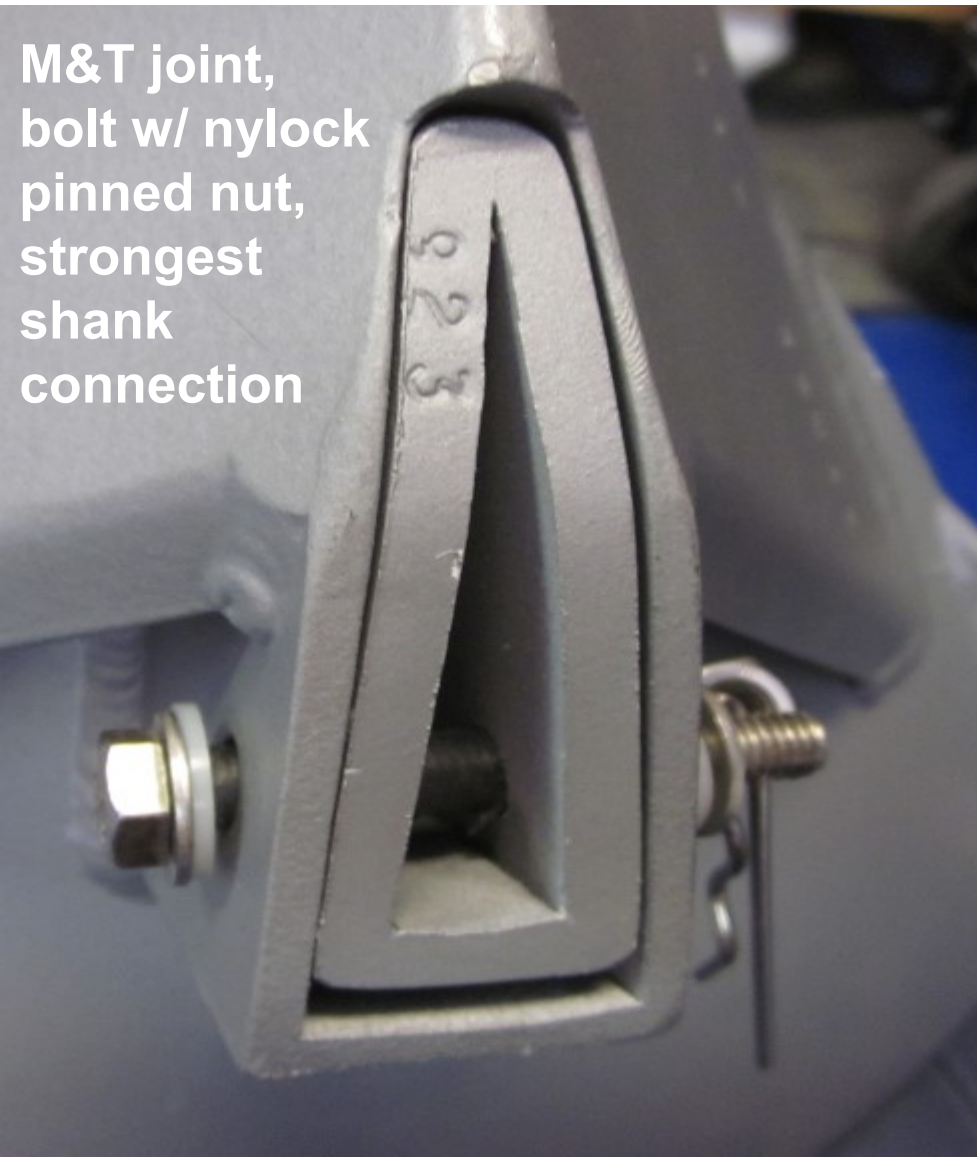

Spade – 316 SS, Alum, Steel



Only anchor available in 316 SS, galvanized HT steel, and aluminum

Spade Characteristics

- One of the top performing Modern Scoops.
- **Most holding tests show at or near the top holding power vs other Scoop anchors.**
- **West 2006 Tests – ‘Multiple pulls resulted in 5000 lb load readings. Results fell off at 3:1 scope and harder bottom.’**
- **PBO 2011 Tests - Stable when dragging. 34 lb Efficiency = 32. Rating – Excellent.**
- Heavily weighted tip, 50% of anchor weight, used to position anchor for setting.
- Shank hollow design reduces high weight while producing good strength, but increases cost.

Spade Characteristics

- **Expensive due to complicated construction**
- Removable high strength, 3 piece, hollow shank.
- **Very stable in bottom if drug** due to triangular base, side wings and skid plate design.
- **Hot dip galvanizing requires lead removal due to open lead filled ballast chamber.**
- **Reported better than roll bar Scoops in weeds, kelp, rock, wind reversals.**
- **Warranty – Lifetime but some limitations if not properly sized, 6 mo full satisfaction guarantee.**
- Made under close supervision at same factory in Tunisia for 18 years.

Oceane Anchor



Less expensive Spade
product, no longer made

Sword Anchor



Successor to Spade's
Oceane, no longer made

Spade SeaBlade Anchor

New 2012 hybrid, Spade w/ roll bar & no tip weight, same design blade and shank as Spade, only in galvanized Fe, < 66#



Spade Spoon Anchor



New, small Bugel knockoff

Raya Anchor



Knockoff to Spade's
Sword

Rocna Anchor 2004



NZ design, concave triangular fluke, high tensile shank, maximum blade area, side wing plates, chisel tip, rear skid plate, roll bar

Rocna



Rocna Anchor

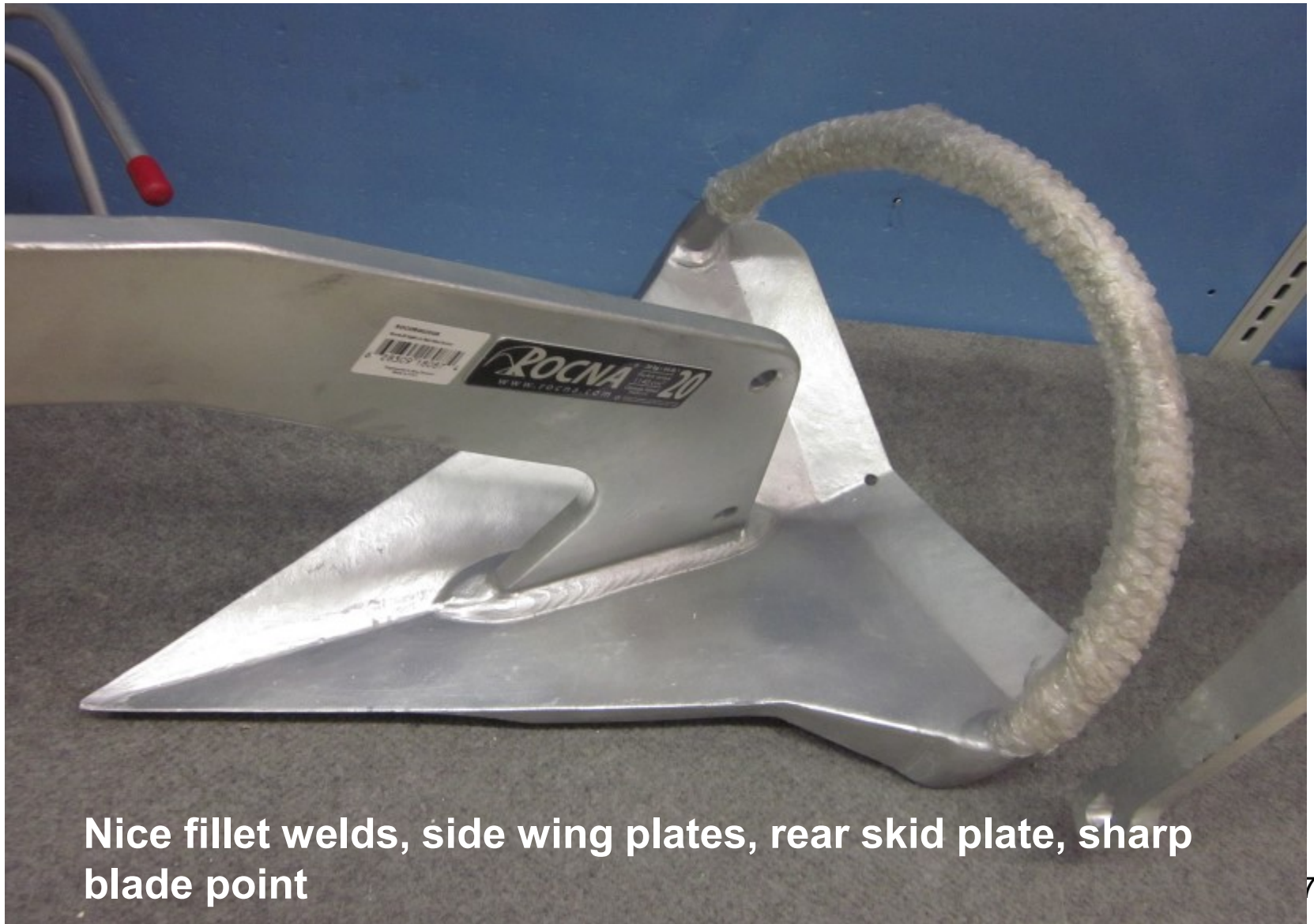

Nice fillet welds, side wing plates, rear skid plate, sharp blade point

Rocna Fluke Tip



Very sharp finely
made chisel tip

Rocna Characteristics

- One of the top performing Modern Scoops.
- **Most holding tests show near the top holding power vs other Scoop anchors.**
- **West 2006 Tests – ‘Consistent performance at all 3 scopes with loads to 5000 lbs. Results halved in hard bottom.’**
- **PBO 2011 Tests - Stable when dragging. 34 lb efficiency = 30. Rating – Excellent.**
- **Lifetime Warranty** against bending, deformation and manufacturing defects.

Rocna Characteristics

- Modern Scoop anchor with high tensile shank and mild steel fluke and roll bar.
- Uses roll bar and geometry, instead of weighted tip, to rotate fluke into bottom.
- **Reported slightly better than Spade at setting in hard bottoms with short scope, and very soft mud.**
- **Some problems setting in heavy grass due to roll bar bases catching grass and tipping blade up.**
- Problem in 2011 with Chinese construction of inferior metal, causing recall. Now resolved.
- **Currently owned by Canada Metal Pacific and made in China under “full quality control of wholly owned subsidiary”.**

Rocna Destruction Test



55 Kg Rocna at 29 tons pull, shank/blade weld holding, but HT shank bent

Manson Supreme Anchor 2006

NZ design, concave triangular laminated fluke, strongest high tensile shank, maximum blade area, side wing plates, chisel tip, roll bar, twin rode attachment.

ENHANCED SHANK
steel shank. Made of steel, the Supreme's is the strongest anchors.

Ensures the anchor
adopt the



ROLLER COMPATIBILITY

conform to all standard bow roller fittings and
self-launch.

HEAD

anchor to pierce the toughest
sea has to offer.

Available in galvanised or stainless steel at your local

Sizes: 5lb, 10lb, 15lb, 25lb, 35lb, 45lb, 60lb, 80lb, 100lb

Manson Supreme



**Rolled instead of
bent concave
fluke**

Manson Supreme Characteristics

- One of the top performing Modern Scoops.
- **Most holding tests show slightly below holding power of top Scoop anchors.**
- **West 2006 Tests – ‘Set quickly and resisted loads from 2500 to 5000 lbs even at 3:1 scope. Results fell off in hard bottom.’**
- **PBO 2011 Tests - Stable when dragging. 25 lb Efficiency = 21. Rating – Excellent.**

Manson Supreme Characteristics

- Similar in design and performance to Rocna.
- Laminated fluke nose with spear shaped tip.
- Made in New Zealand of **Bisplate 80** and Grade 350 steel. Lloyd's certified SHHP.
- Twin attachment slots assist in fouled anchor retrieval in rock and coral.
- **May have problem setting in grass due to roll bar.**
- **Lifetime Warranty** against manufacturing defects **but not bending.**

Manson vs Rocna Wars!

History, construction, and testing

2006

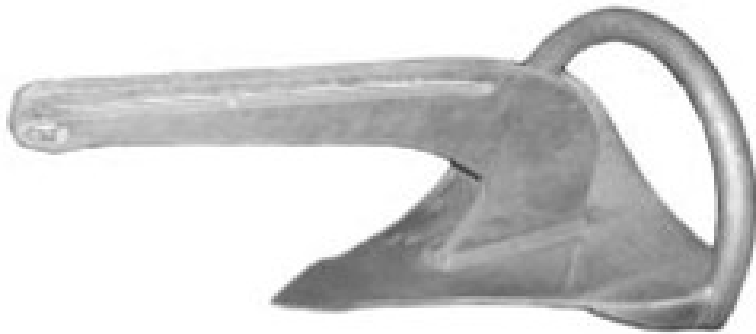

Manson Supreme

2004



Original Rocna

Did Manson copy Rocna?

Manson vs Rocna



1



2



ROCNA



MANSON SUPREME

Manson Supreme vs Rocna

2006



The 2006 SAIL testing illustrates inconsistent performance from the Supreme. Here, the 35 lb Supreme performs comparably with the smaller 32 lb genuine Rocna in two of three locations, but proves unreliable "west of wharf"

2011

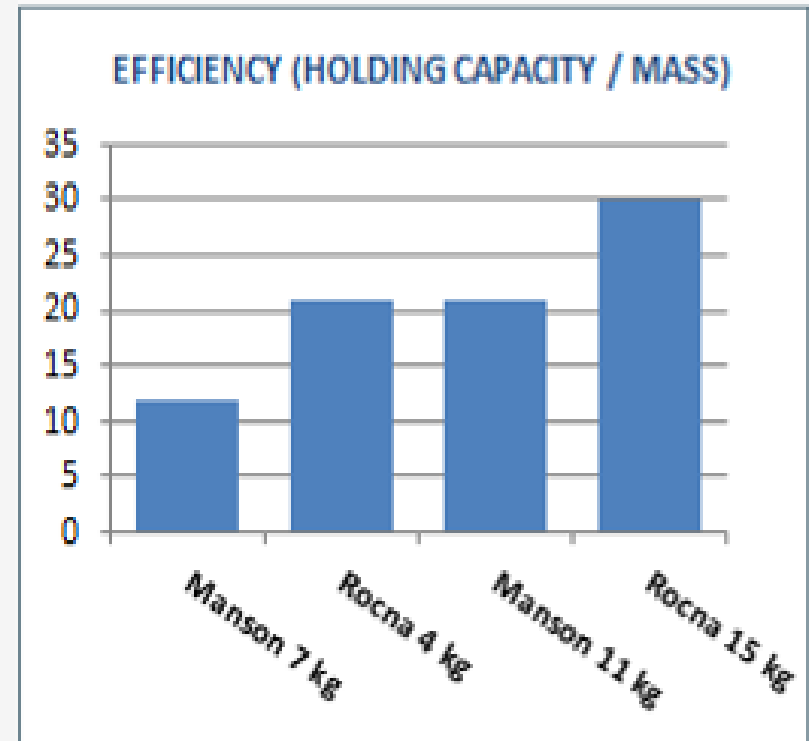

Low efficiencies from the Supreme in the 2011 Practical Boat Owner testing. In both size classes the Supreme gives quite different weight-for-weight performance.

Manson Supreme vs Rocna

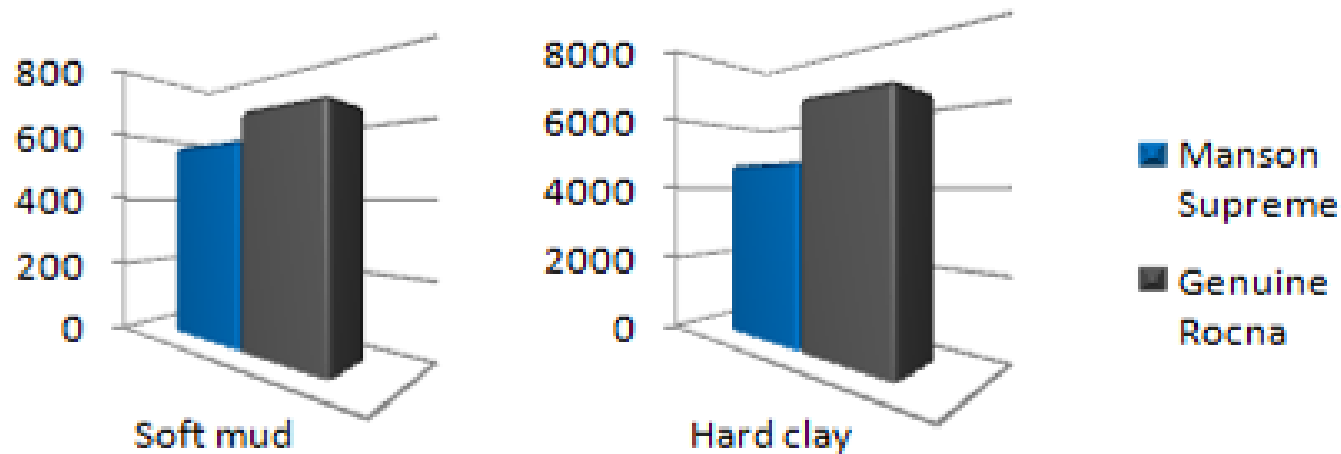

SHHP seabed testing conducted and certified by RINA demonstrates significant differences across different seabeds even in simple straight line performance.

Ultra Anchor 2006



Hand made only in
316L SS, hollow
reinforced tubular
shank, lead filled
curved enclosed tip,
side wings, non foul
bar, reinforced eye

Ultra SS Anchor

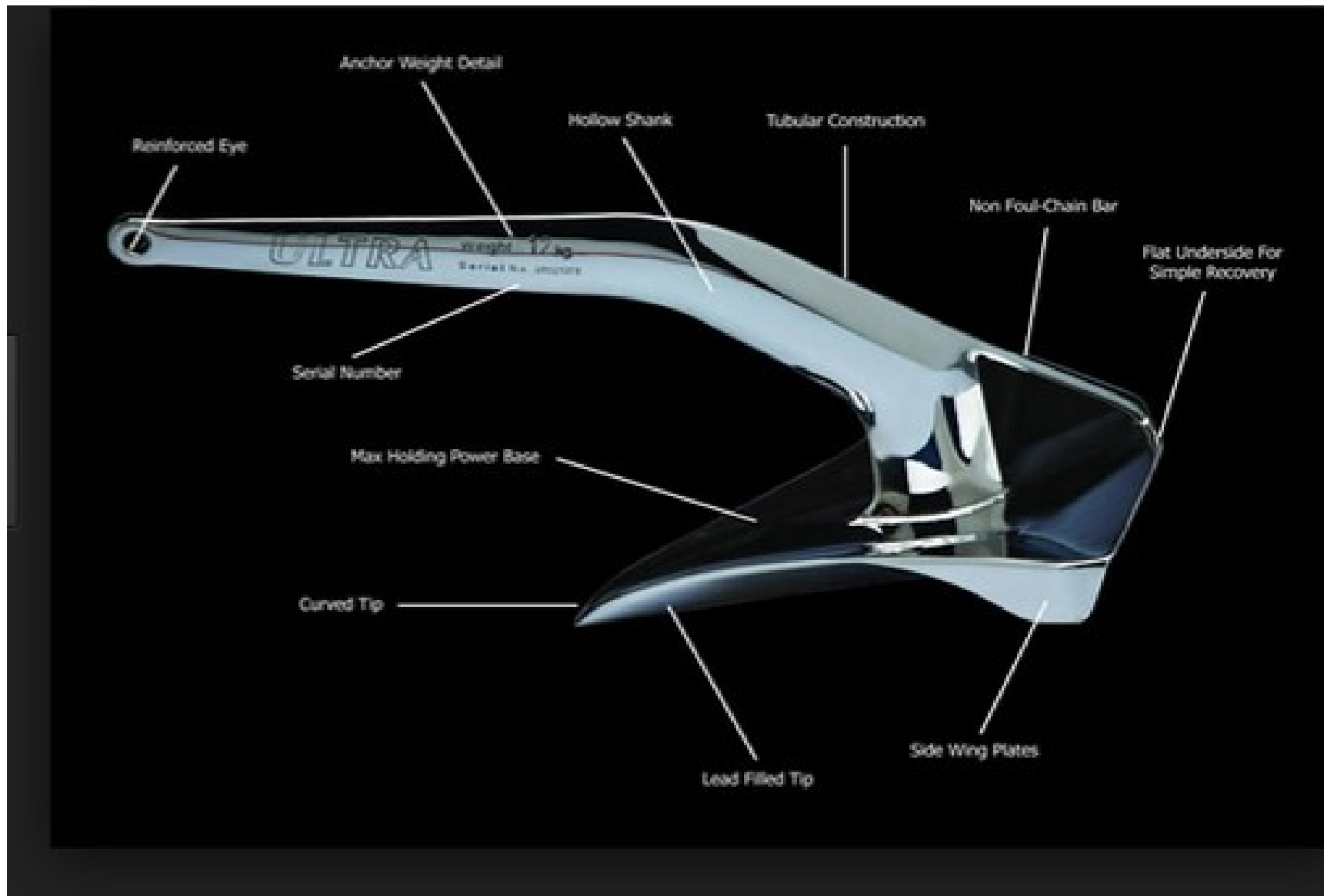

Ultra Anchor Characteristics

- Excellent design.
- Non foul chain bar aft prevents rode fouling.
- Reverse curved tip for quick deep set.
- ABS Superior Holding Power and ISO certification.
- **Lifetime all encompassing Warranty.**
- **Very expensive. 3x cost of galvanized MGS anchors.**

Ultra Anchor Characteristics

- Made in Turkey by Boyut Marine; US distributor Quickline USA
- **One piece of handmade polished 316L SS, not as strong as HT steel.**
- Self righting & quick setting due to lead weighted base.
- **Reinforced tubular shank** greatly resists side load bending.
- Side wing plates help rapid setting and keep anchor in bottom during lateral loads from wind shift.

Mantus Anchor - 2012



MGS Scoop w/ roll bar, shank made of A 514 HT, sharp chisel fluke tip

Mantus Anchor



**3 part disassembly
for storage, plus
nuts and bolts**

Mantus Characteristics

- Promising Modern Scoop w/ roll bar designed for grass and hard bottoms.
- Came to **market in late 2012**, so not much independent testing yet.
- Can be **completely disassembled**.
- Made in China of A36 mild steel under close supervision of company engineer.
- Shanks made of ASTM 514 HT steel.
- **Lifetime warranty, including shanks and shipping!**
- Recent positive tests and reviews so now a major player in anchor market.
- Company makes innovative other ground tackle products like swivels, chain attachments and anchor mounts.

New, Specialty & Other Anchors

- Knox
- Rocna Vulcan
- Super Max
- Danforth
- Fortress/Guardian
- Super Sarca
- Hydrobubble
- Barnacle
- Bulwagga

Knox Anchor 2013



Interesting MGS roll bar design, two half flukes. See www.knoxanchors.com for more details.

Knox Anchor

The Knox Anchor provides the highest holding force per unit weight of any commercial yacht anchor and it offers unrivalled anchoring security.

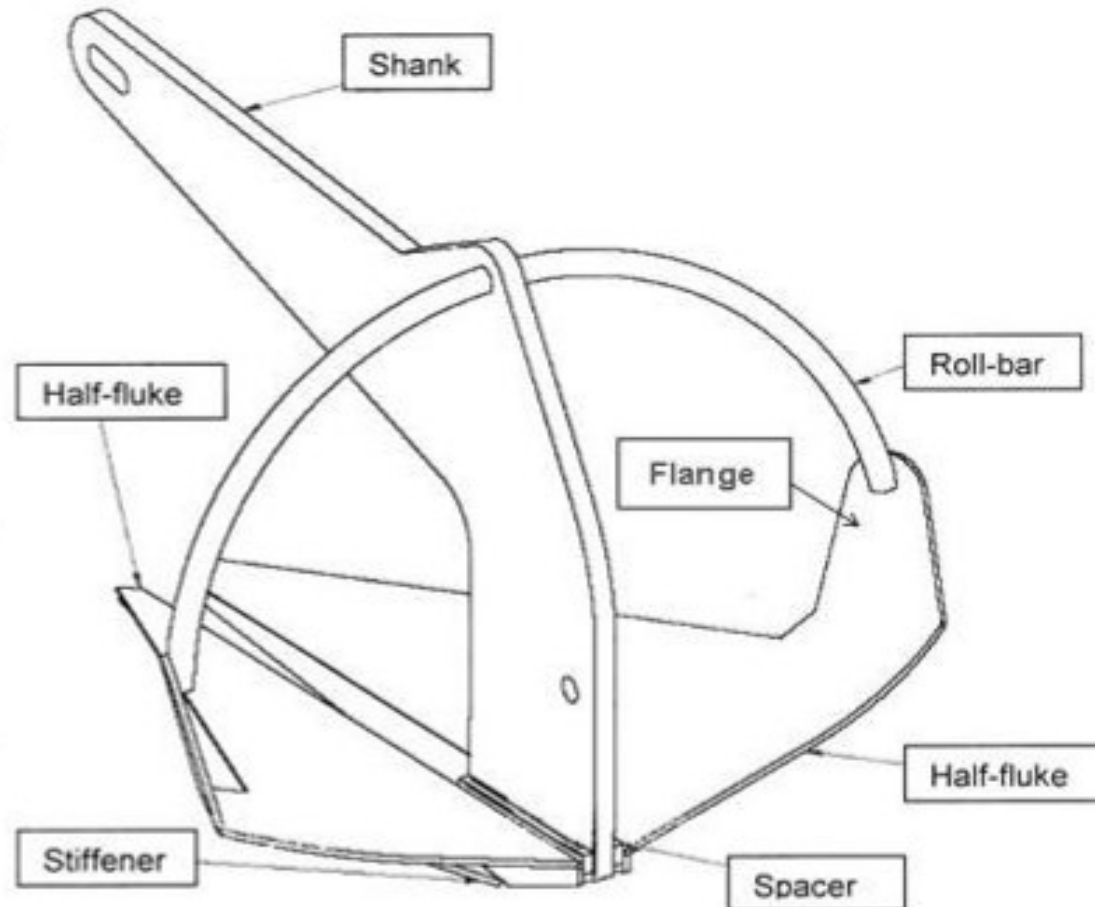

We HAVE MEASURED THE Ultimate Efficiencies of a range of well known anchors in tests carried out in medium-hard sand at Longniddry Beach on the south side of the Firth of Forth as shown in the table.

Anchor Type	Ultimate Efficiency	Overall Performance
Galvanised Steel		Ease of engagement in hard seabeds
KNOX	>40	Excellent
Spade	>25	Excellent
Rocna	>25	Excellent
Manson Supreme	20	Very Good
Delta Type	8-12	Good but sometimes slow to embed
CQR Type	6-8	Poor. Holds then rolls out in a cyclic manner when forced to plough. Prone to dragging
Bruce Type	4-15	Poor to good. Efficiency sensitive to exact design. Beware of poor copies.
Danforth Type	20-30	Very good to excellent; often one half fluke digs in initially. Beware of unsymmetrical fluke design.

Dr Knox Anchor Setting Test Results from his website. No recent Knox vs other MGS anchor tests.

Knox vs Other MGS Anchors

Comparison of Knox Anchor vs. other new generation anchors



Source Knox website- The chart compares the development of the holding force of the Knox Anchor with those of a range of other new generation anchors in the weight range from 11 to 16 kg. The holding force to weight ratios of the new generation anchors are very similar and appear to reach maxima between 20 and 30. The maximum holding force to weight ratio of the Knox Anchor is around 40, 30-100% greater than that of the other new generation anchors we have tested.

Rocna Vulcan Anchor 2014



Rocna Vulcan Information

- First introduced after extensive design and testing at Ft Lauderdale Boat Show in 2014.
- **Website has no independent testing results.**
- **SHHP classification**
- Passes eye test for strength, balance, good construction details. **Looks to be equal to other New Generation Scoop anchors with no roll bar.**
- **Lifetime warranty** against breakage, bending, and defects
- **Currently made by Canada Metals with pricing similar to Rocna/Manson**

Spade vs Vulcan Anchor War?

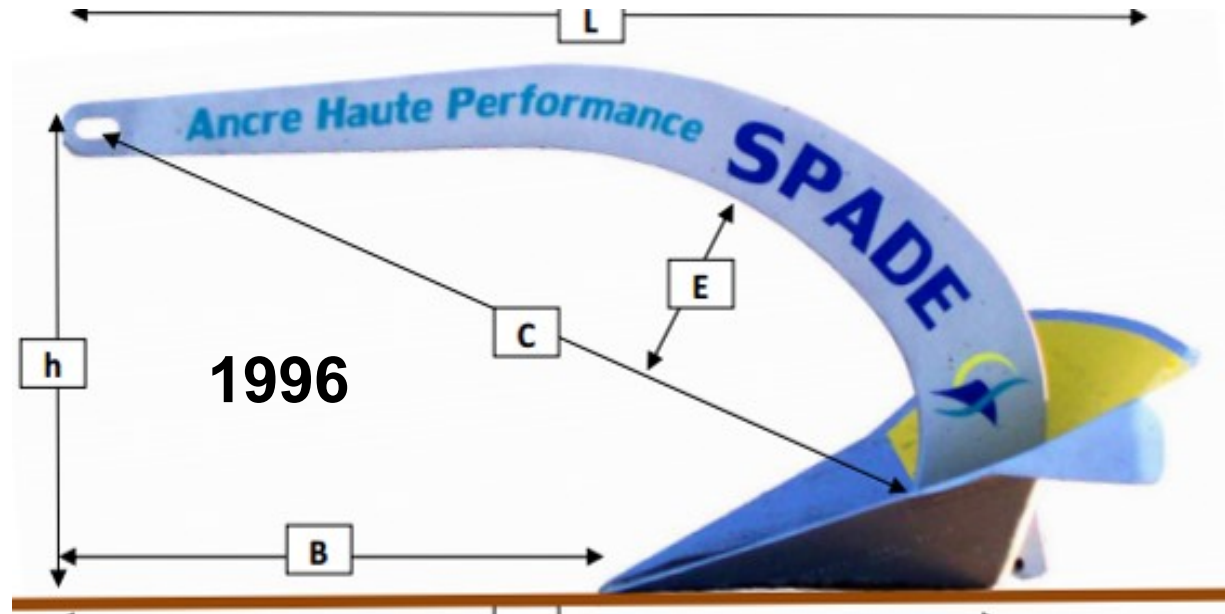

Super Max Anchor Mid 1990s



US built by Creative Marine, wide shovel fluke w/ 3 blunt tips

Super Max Characteristics

- **Made in USA by US company.**
- Fixed or adjustable shank.
- Excellent holding power once set in soft bottoms due to large scoop fluke area.
- **Difficult to set** in grass and harder bottoms due to **wide fluke front.**
- Not widely tested with other modern anchors.

Danforth Anchor -1948

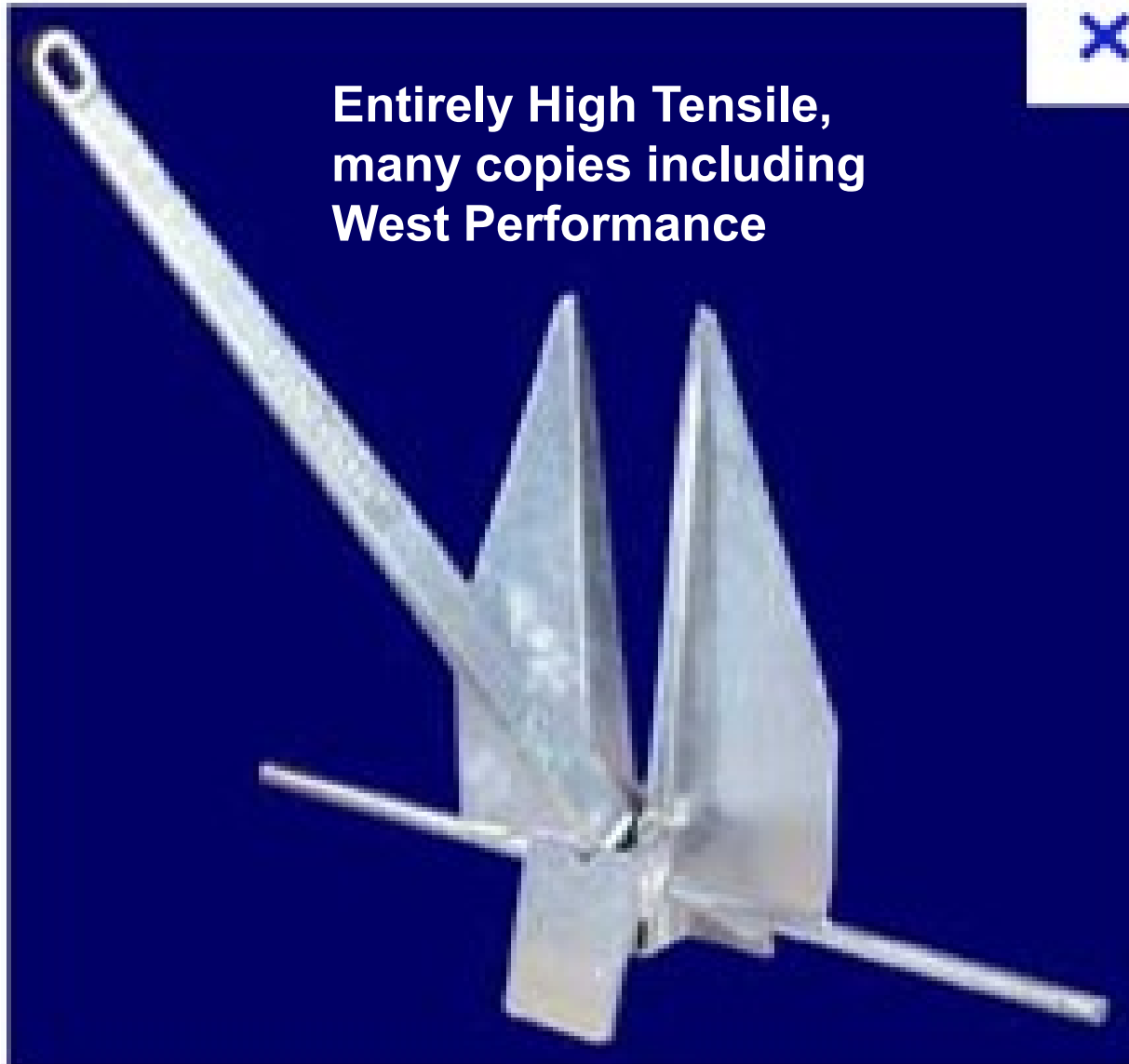

Danforth/West Characteristics

- **Not suitable as Primary anchor, great as a stern or soft mud anchor.**
- **West Tests 2006** – (West Perf - 26 lb)
'Disappointing results considering previous tests. Held 200 to 1,500lb.
- Skates along surface of hard and grass bottoms.
- Unable to reliably handle veering winds.
- **If drug after setting (e.g. in soft mud), strong tendency to trip on one fluke and roll out.**
- Reduced strength and durability due to design.
- **Must be used in homogeneous soft bottom, can't point load.**
- **Danforth HT usually tests better than West Perf.**

Fortress Anchor – Mid 1980s



Made in FL, take apart & adjustable for mud and sand, precision machined w/ very sharp edges

Fortress Characteristics

- **Not suitable as Primary anchor, great as a stern or soft mud anchor.**
- **Highest quality construction** of precision machined marine grade 6061 T6 aluminum
- Carefully engineered tapered shank effectively disperses loads, resists bending.
- **Large fluke surface area gives great UHC.**
- Consistently **superior holding performance in independent testing** (2-300 x weight) due to largest fluke area for anchor total weight.

Fortress Characteristics

- Careful strengthened structural design at high loading points effectively compensates for aluminum's susceptibility to deformations.
- In US Navy tests in 1989 and most other holding tests Fortress **out performs much heavier anchors including Danforth HT.**
- **Once deeply set in a homogeneous bottom in strong winds anchor will not budge.**
- **Lifetime warranty for ANY damage.**

Fortress Guardian Anchor

FORTRESS

GUARDIAN

COMMANDO



Development, Guardian offers
is made from the same high
quality and manufacturing precision

Elimination of some of Fortress'

Less expensive Fortress, no adjustment

Super Sarca Anchor

**Sand and Rock Combination
Anchor, weak design for a
Primary anchor**



Barnacle Anchor



No longer made, weird design but good holding characteristics in testing

Hydrobubble Anchor



Promising performance but now out of business

Bulwagga Anchor

Really weird
design, no longer
in production,
mainly for weeds

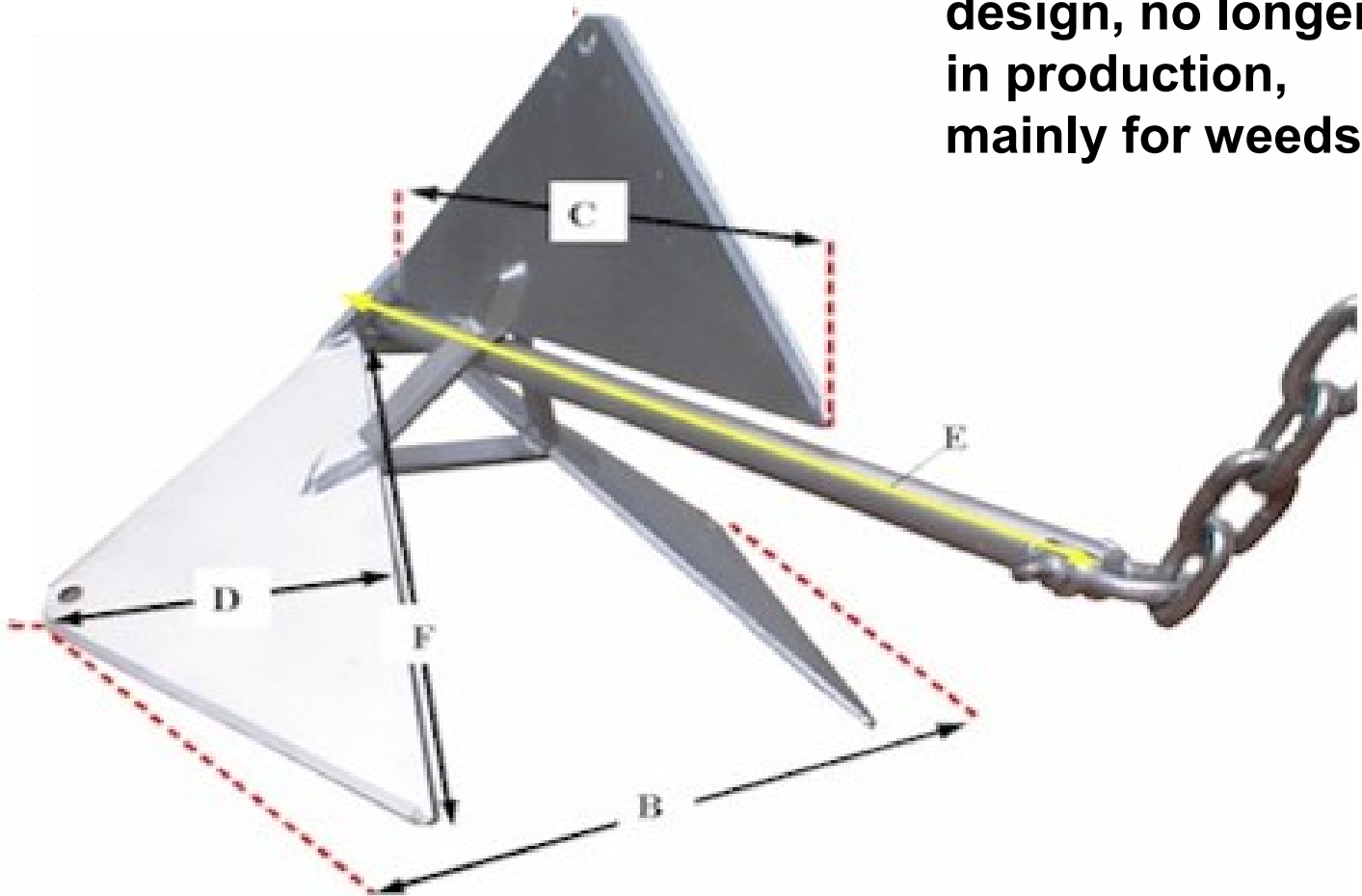

Anchors with Long Slots

- Designed to ease retrieval if anchor fouled on bottom
- **Not a good cruising feature** because of danger of big wind shift breaking anchor loose
- Use only for **day anchoring** in rock/coral while aboard



Anchor Problems



**Bruce w/ coral rock
caught in fluke basket**

Corroded Spade



SS CQR Knockoff w/ Broken Shank



Delta w/ Bent Shank



Anchor too small for boat size,
33# anchor on 41' Morgan OI

Rocna w/ Bent Shank



Bent Rocna Shank



Weak Chinese Steel?

CQR w/ Bent Shank



CQR Rusted Through



Homemade Rusted Scoop



**Wow! Fijian
craftsmanship**

Badly Rusted Brittany



Corroded CQR, Shackles, Chain



Fortress Point Loaded

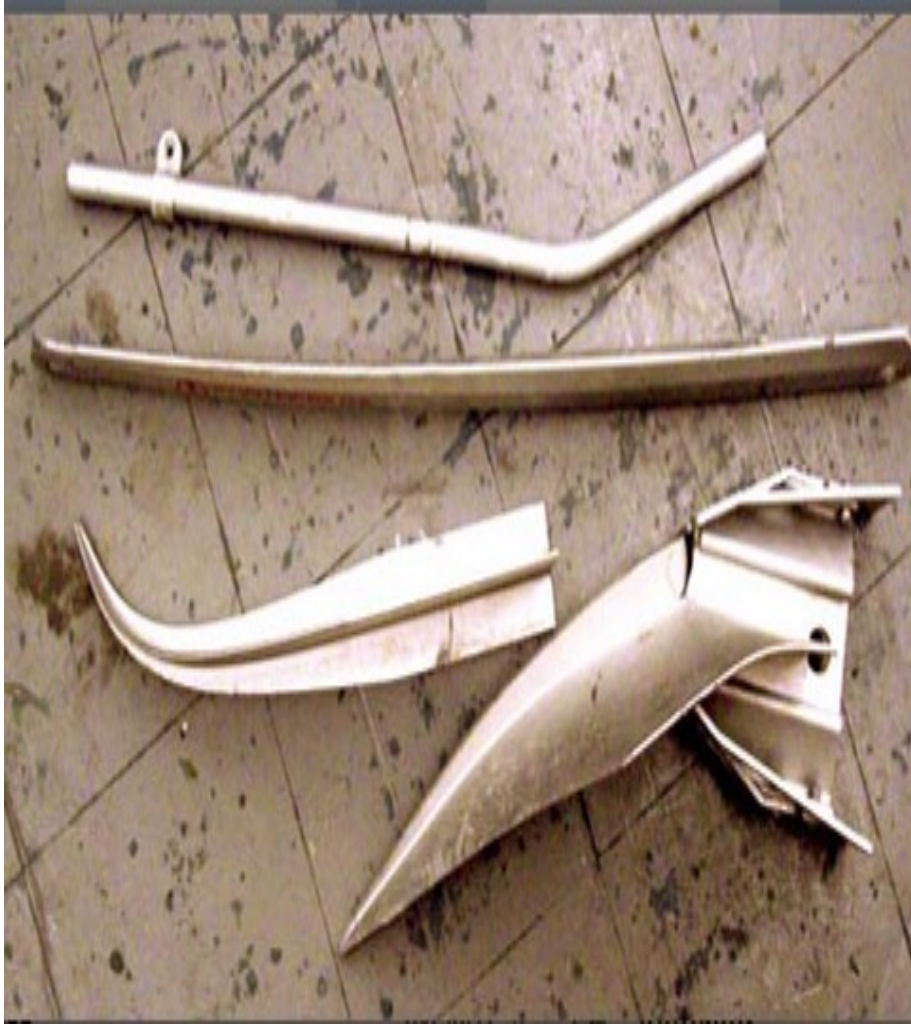

Anchor Testing

- Look at 4 recent tests
- **Best use is comparison not individual results**
- Bottom type critical to results
- Tester analysis not always accurate
- **See Rocna/Peter Smith website for good analysis of many anchor tests.**



2006 West Anchor Test Results

(UHC, DHF and Setting)

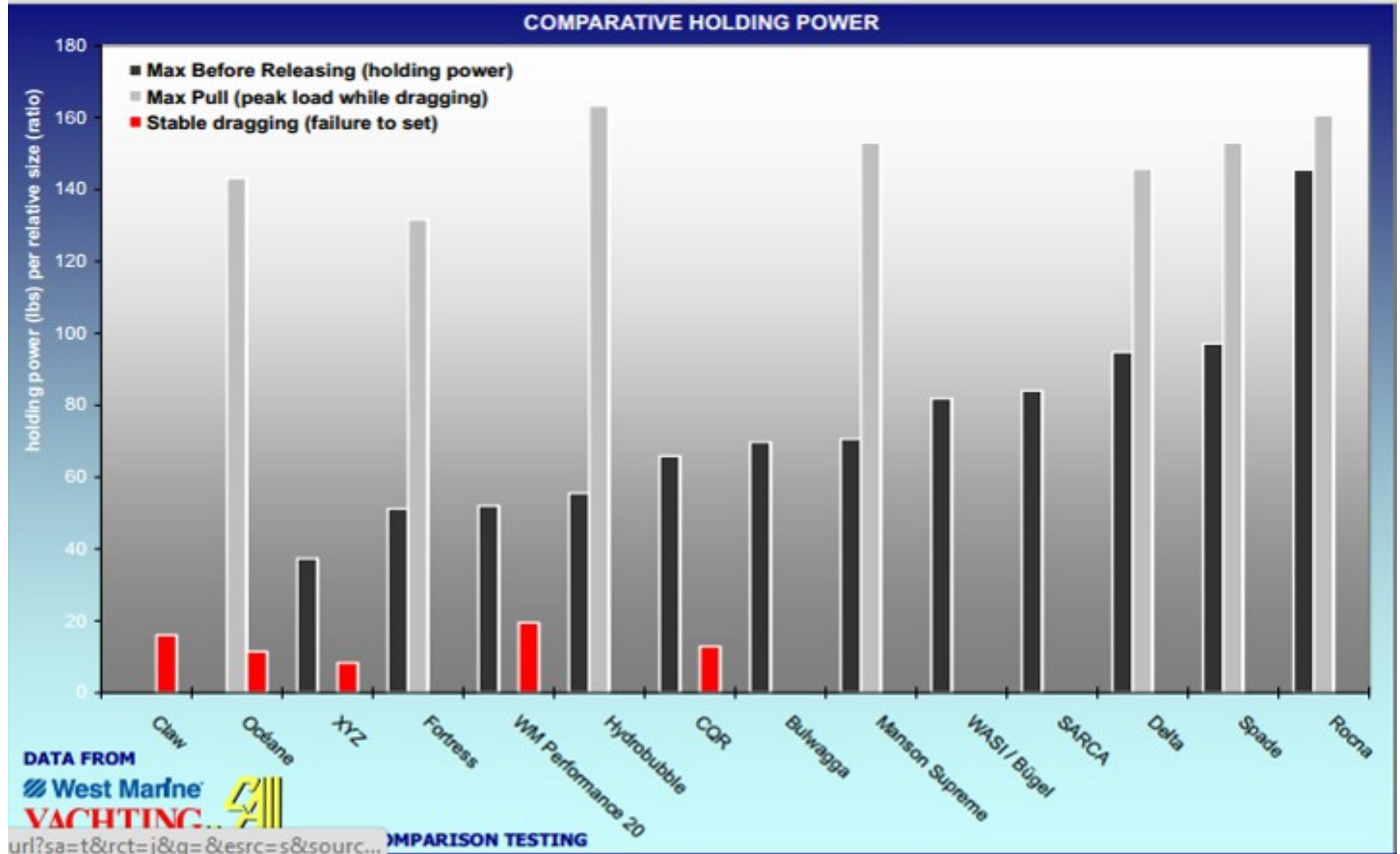

2009 Voile Anchor Test Results

(Veering and Dragging)

anchors.

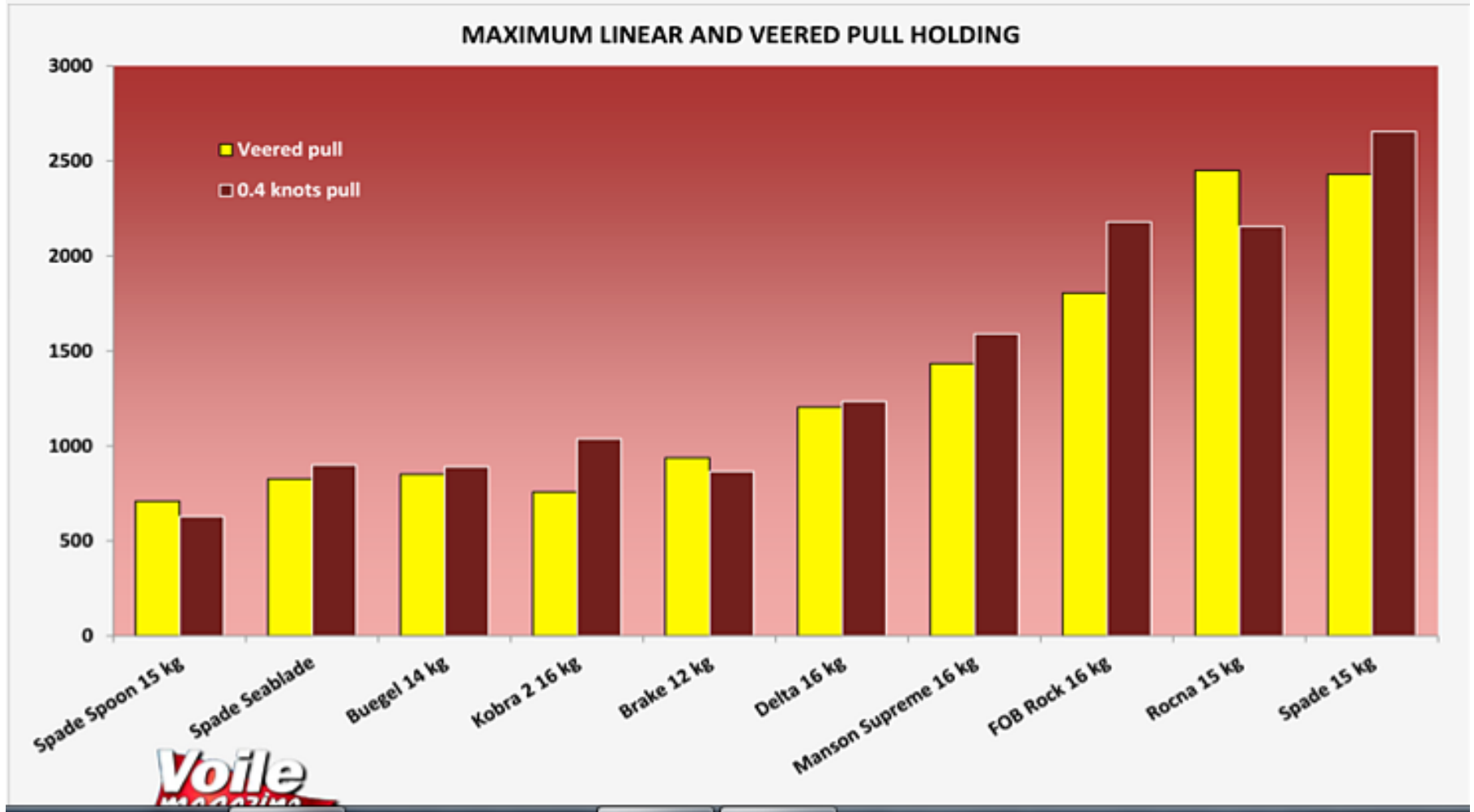

2011 PBO Anchor Test Results

(UHC and Efficiency Using Actual Sizes)

HOLDING CAPACITIES & EFFICIENCIES

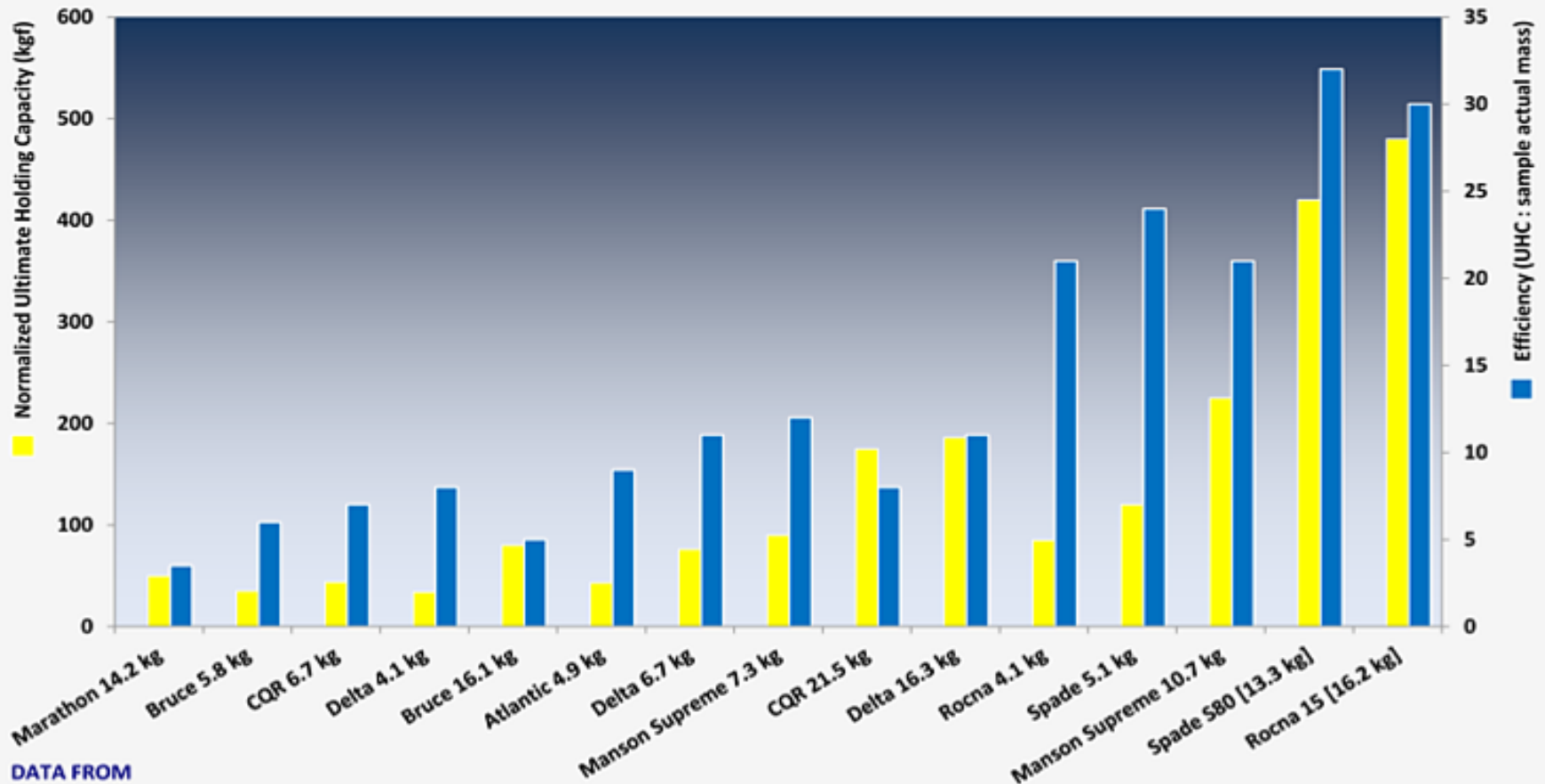

DATA FROM
Boat Owner 2011 COMPARISON TESTING

Normalized UHC (Ultimate Holding Capacity) and efficiency ratings data
 "Anchors Aware! Anchors On Test" Professor John Knox *Practical Boat Owner* August 2011

2011 PBO Anchor Test Results

(Efficiency Using Nominal Sizes)

EFFICIENCIES BY NOMINAL SIZES

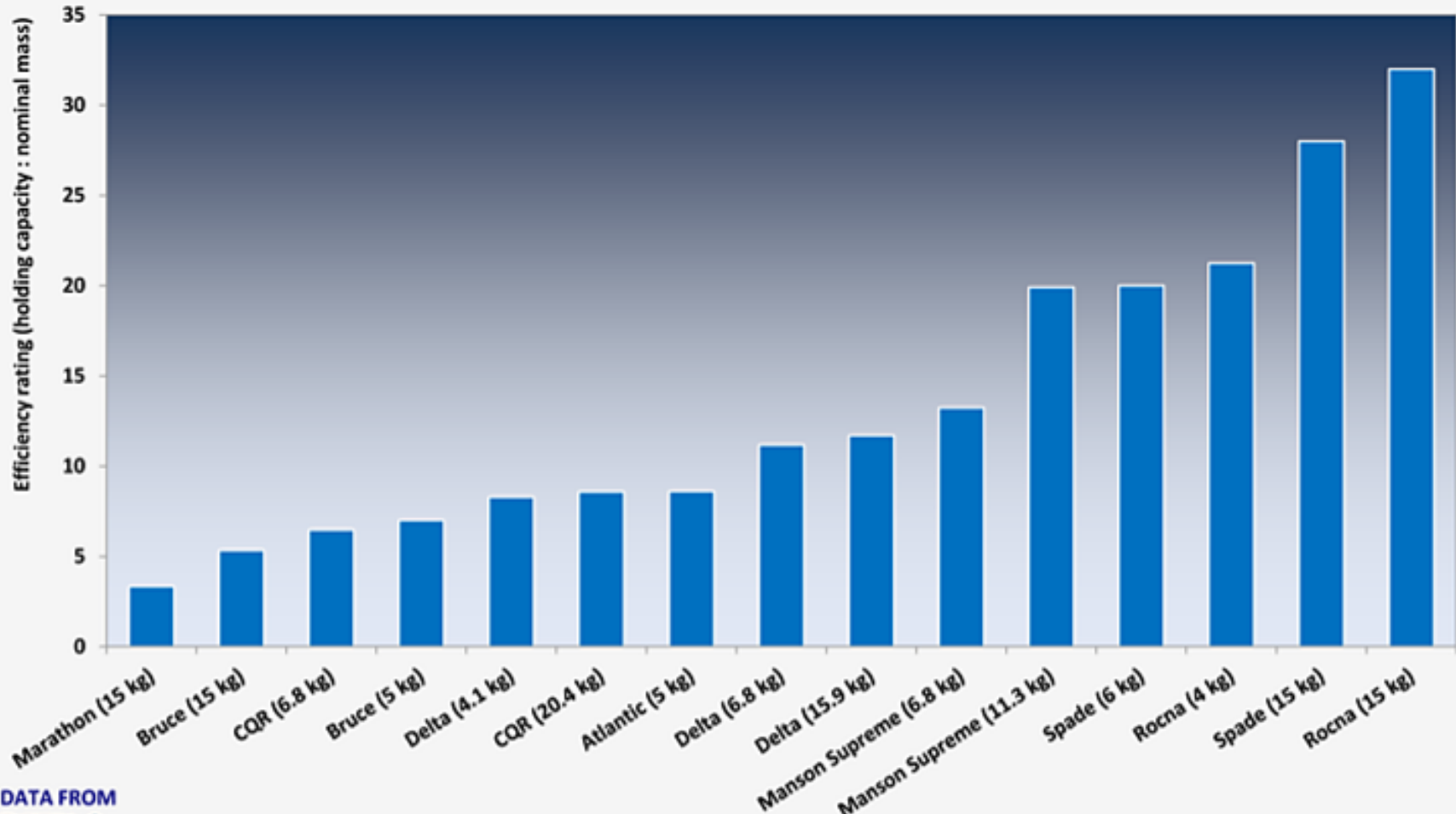

DATA FROM

Boat Owner

2011 COMPARISON TESTING

Efficiency falls off with decreasing size

My Anchor Ratings

Type	Hld	Rst	Drg	Str	La/St	Snd	Mud	Co/R	Grs	Tot
Hook	2	1	1	5	2	2	1	5	2	21
Fluke	4	2	3	2	3	4	5	1	3	27
Claw	3	5	3	5	4	3	2	4	3	32
Plow	3	4	3	4	4	4	2	3	3	30
Scoop	5	5	5	4	4	5	4	3	4	39
Scoop w/bow	5	5	5	4	3	5	4	3	3	37
All characteristics have equal weight, not real world! Useful as relative analysis. 5 – best, 1 - worst										175

Q & A Anchors



STORM ANCHORING

Typhoon Haiyan, 7 Nov 2013
Probably strongest ever
195/235 mph, 26.43 in

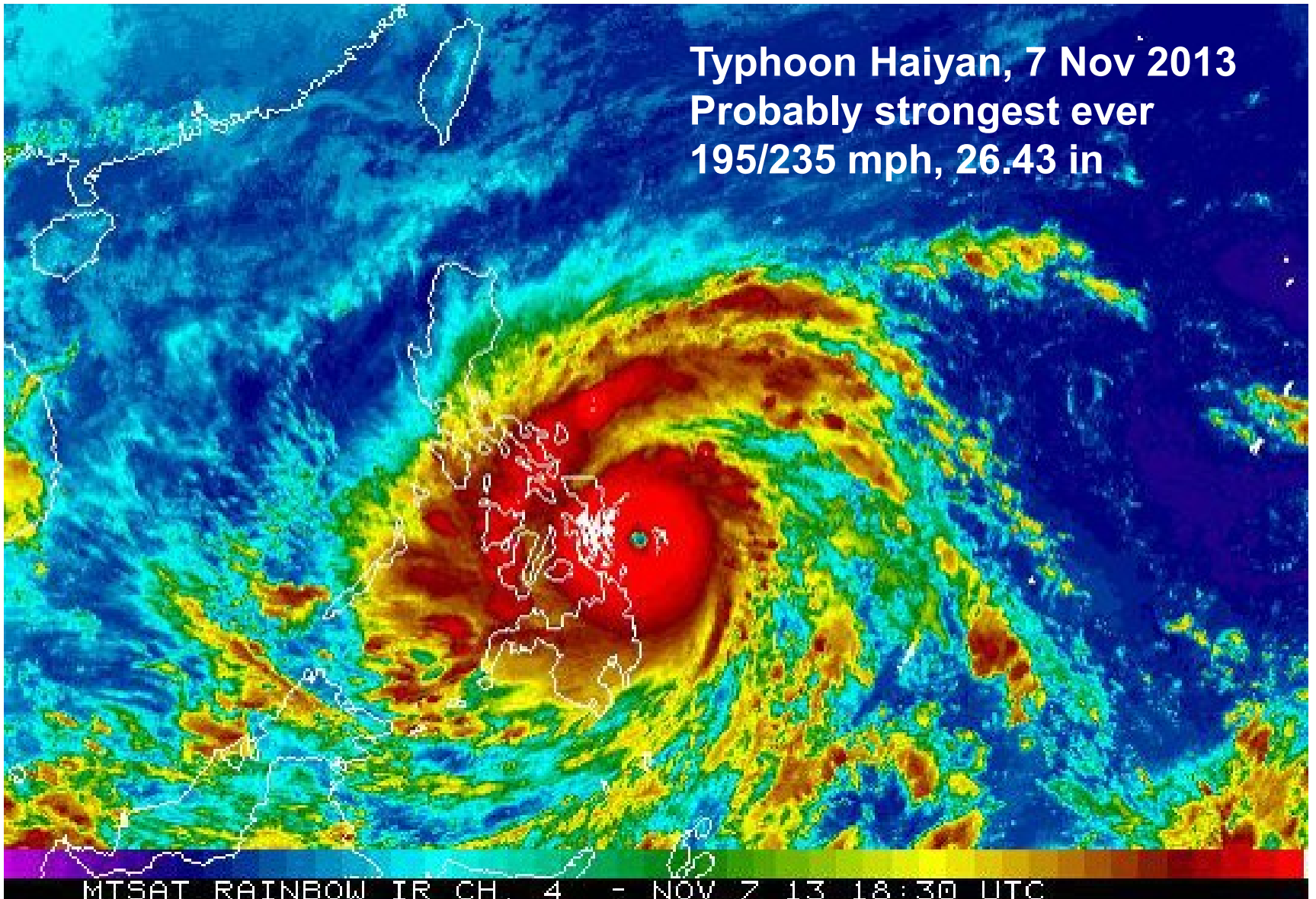

SPaws Anchoring in 60 Knots Rig

(No prior planning)



MGS = Modern Generation
Scoop

- Surprise 60 knot nite storm
- All chain, no weak links
- Strong, long nylon snubber
- Single MGS anchor well set
- Boat length ft + weight Klbs = Delta anchor weight
- Example Delta on CSY 44:
44' + 40K lbs = 84 lb
- MGS anchors exhibit better holding and performance
- Also see anchor websites₁₇₈

Setting Two Anchors

- Parallel V – limited help, multiple issues
 - More difficult to set and retrieve
 - Boat hangs to one anchor if wind shifts
 - Any dragging may foul anchors
 - May be out of step w/ other boats
 - Useful to help maintain position
- Tandem – bad idea, see Smith/Poiraud
 - Very difficult to get both anchors well set
 - Any wind shift may cause complications
 - Must use same type and equal weight anchors
 - See www.petersmith.net.nz/boat-anchors
- Bahamian – solves specific wind/current issues
 - Rodes led from bow or bow & stern
 - Not for use in high winds

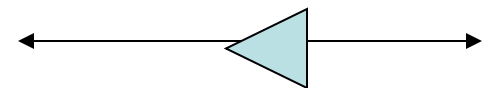
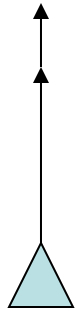
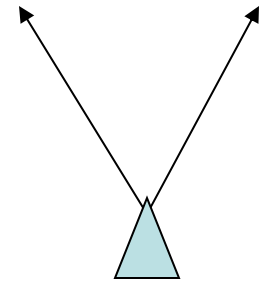

- Bottom Line – use properly sized single MGS anchor unless laying a 3 point mooring.

SPaws 3 Point Cyclone Mooring Rig

(over 60 knots, requires prior plan/rigging)

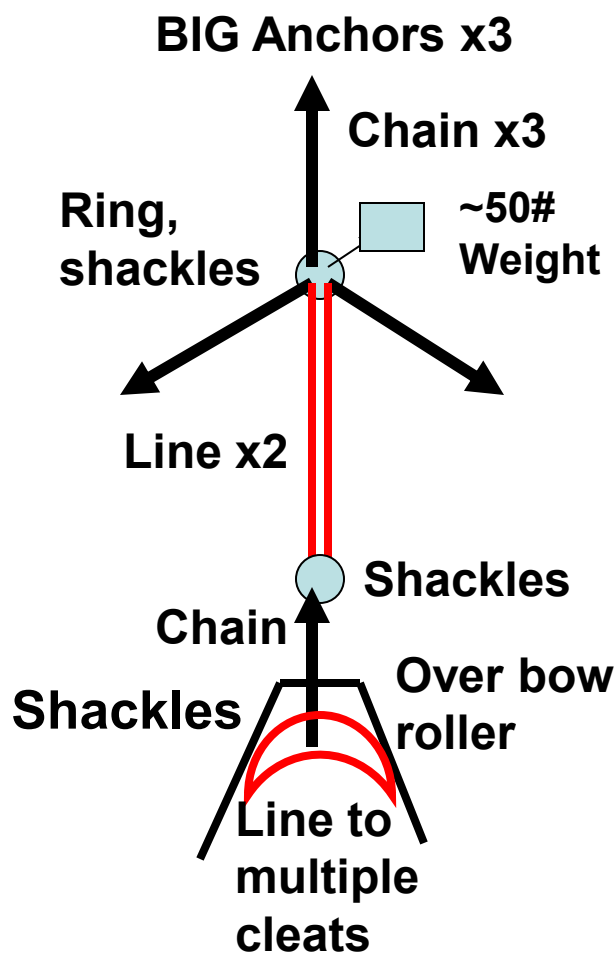

- 3 big strong anchors
- 3 50' HT chain legs
- Strong center ring with BIG sentinel weight
- 2 nylon lines to surface
- 10:1 scope
- Chain over roller
- Multiple lines to bow cleats, spread the load!
- Full strength hard or soft shackles
- No weak links!

SPaws Cyclone Mooring Rig

Line to multiple cleats on deck, chafe gear as needed, shackled to chain

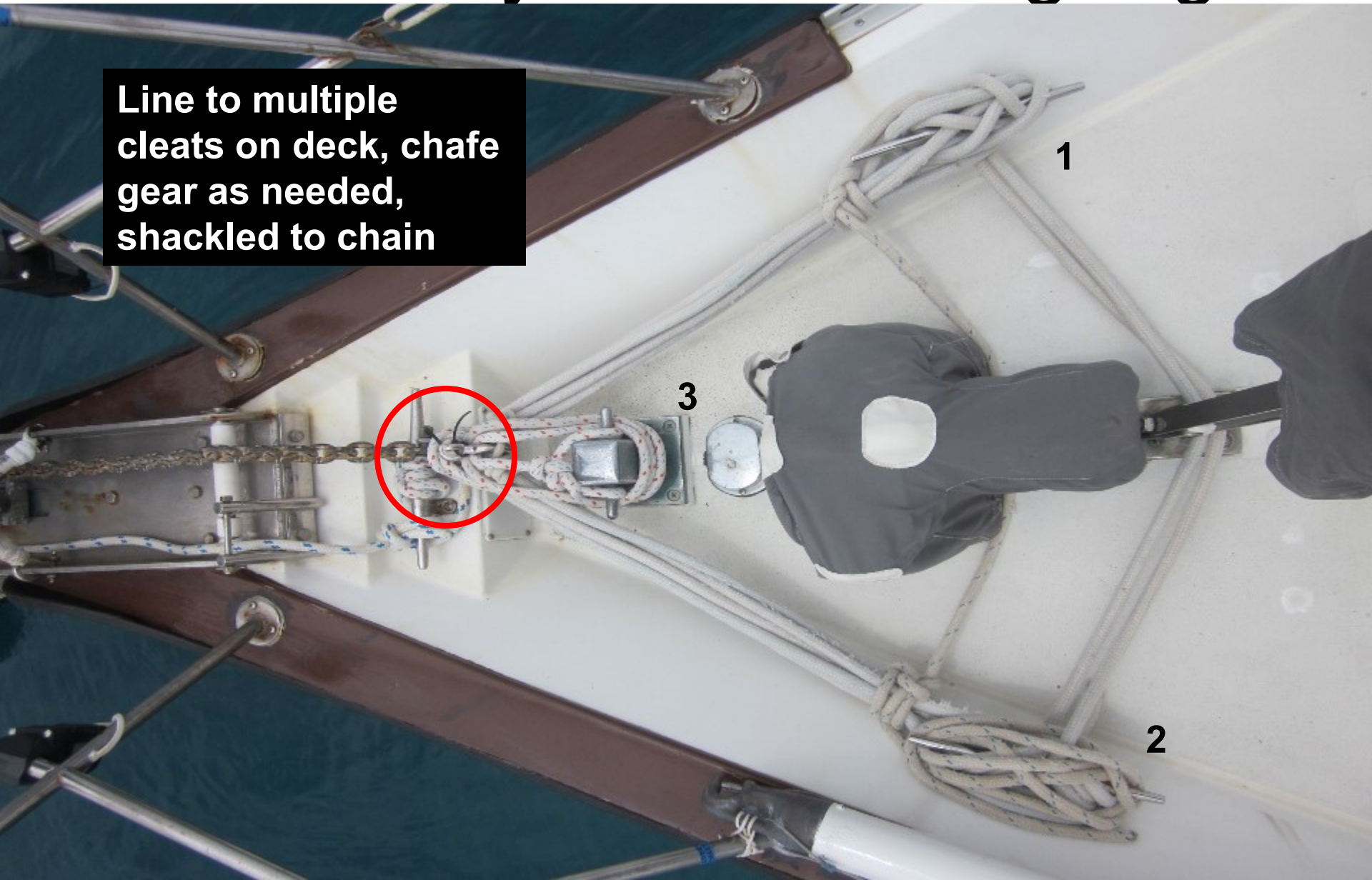

1

3

2

SPaws Cyclone Mooring Rig

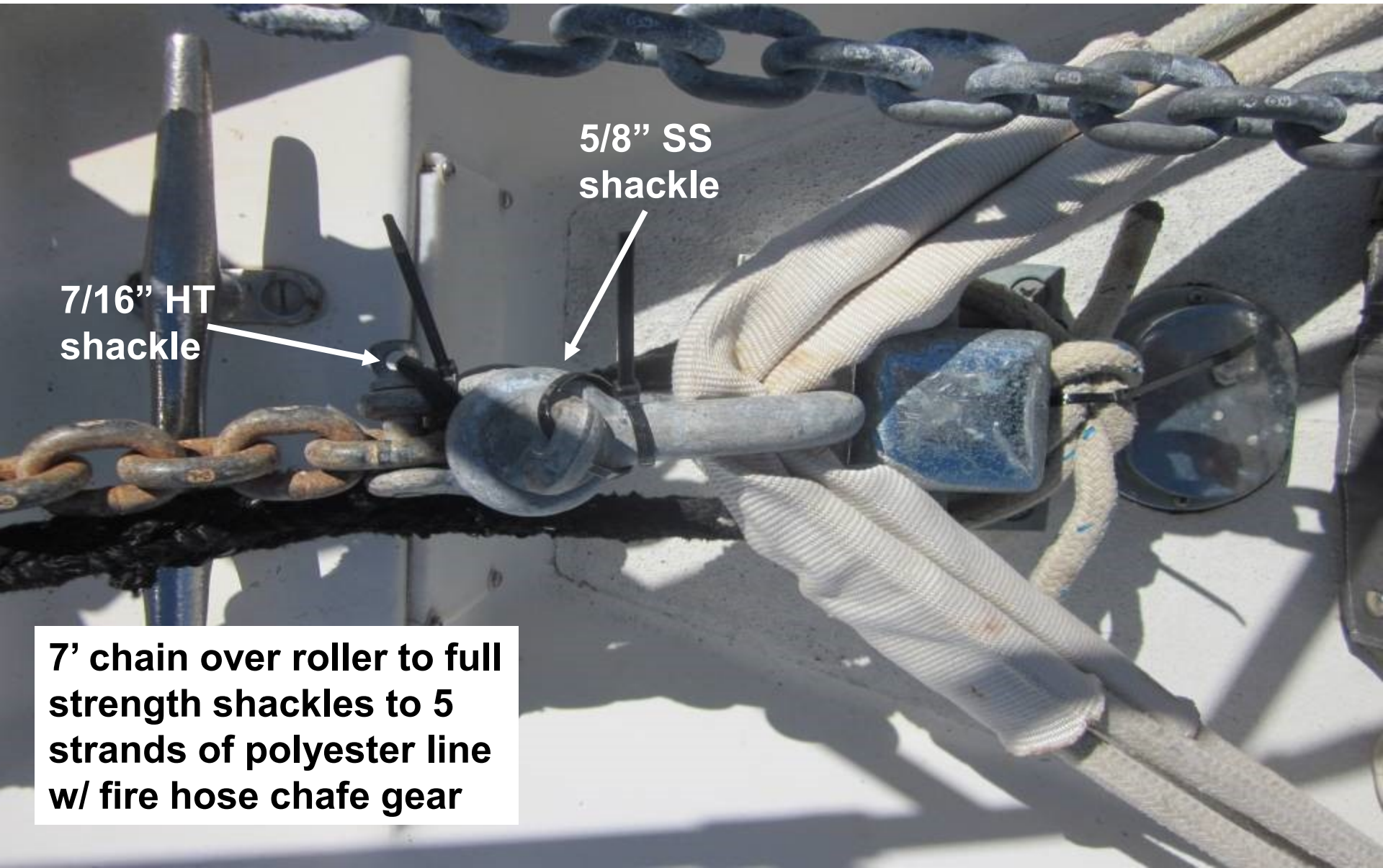

5/8" SS
shackle

7/16" HT
shackle

**7' chain over roller to full
strength shackles to 5
strands of polyester line
w/ fire hose chafe gear**

SPaws Cyclone Mooring Rig

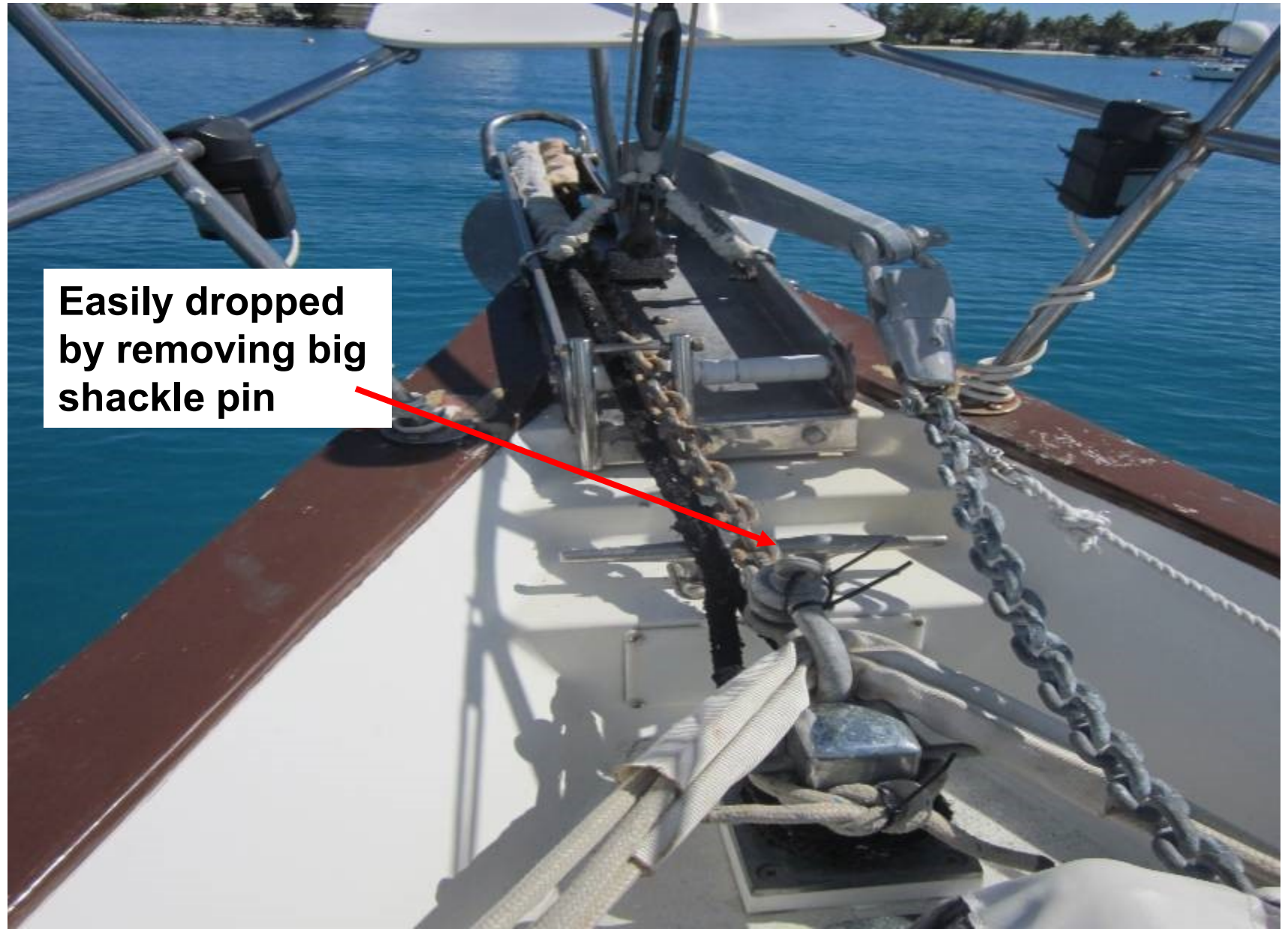

Easily dropped
by removing big
shackle pin

SPaws Cyclone Mooring Rig

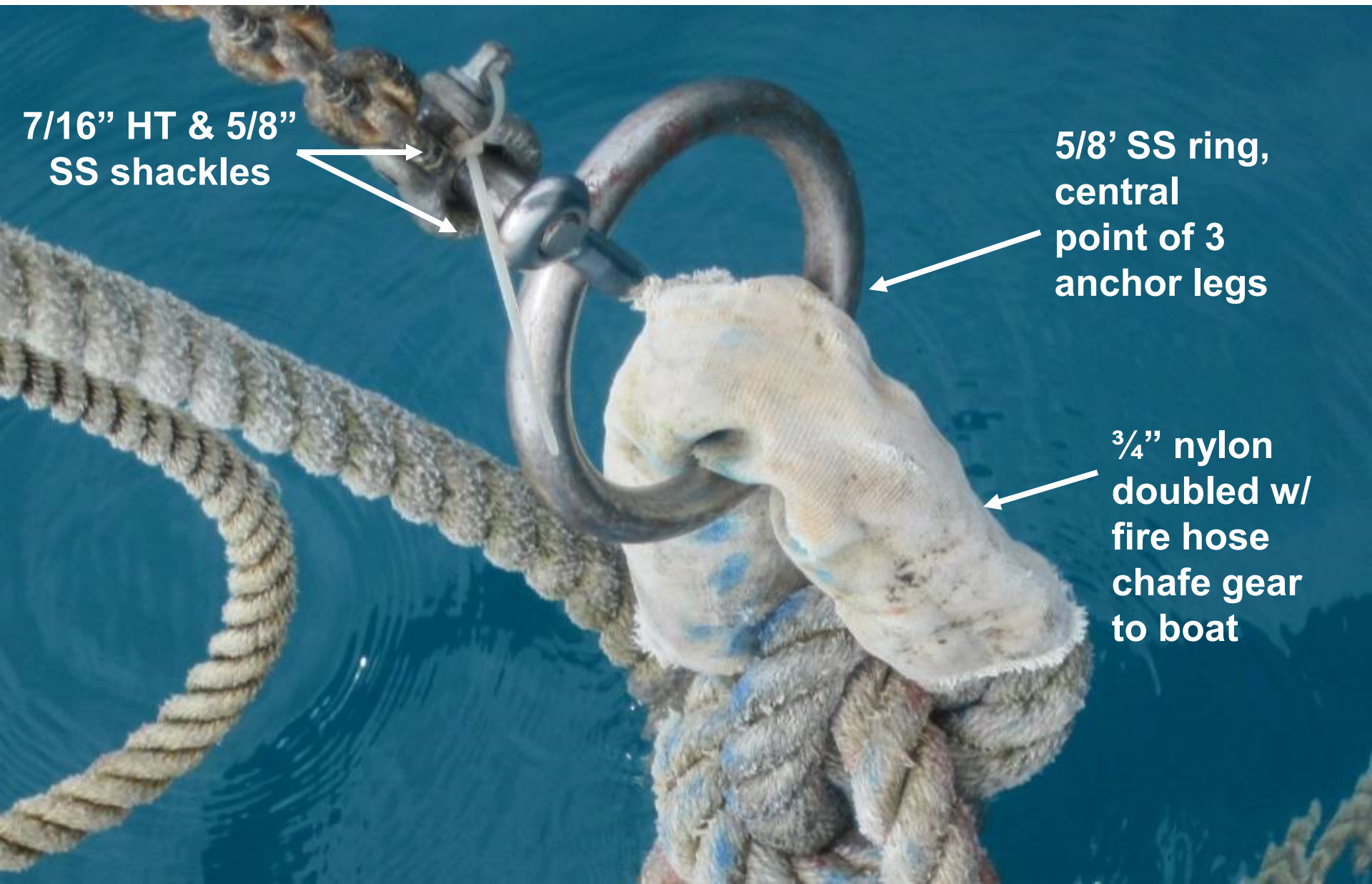

**7/16" HT & 5/8"
SS shackles**

**5/8' SS ring,
central
point of 3
anchor legs**

**3/4" nylon
doubled w/
fire hose
chafe gear
to boat**

Summary

- Choose biggest/best MGS anchor possible
- Anchor with only ONE anchor unless using mooring
- Use G4 chain with full strength hardware
- Use all chain with strong nylon snubber
- Spread the snubber load on deck in heavy winds
- Use minimum 70' chain rode **always** and minimum 4-1 scope unless in over 50' depth
- Use proper anchor setting technique and use it every time you anchor
- Carry additional anchors for storms and difficult situations
- Plan well ahead for serious storm conditions

REFERENCES



**Soggy Paws at Fatu
Hiva, F Polynesia**

Anchoring Books

- **The Complete Anchoring Handbook** – Alain Poiraud, 2008
- **Happy Hooking – The Art of Anchoring** – Alex and Daria Blackwell, 2010
- **Guide to Anchors and Anchoring** - eBook by David Lynn 'Nine of Cups' – 2014
- **The Complete Book of Anchoring and Mooring** – Earl Hinz, 2001
- **Cruising Handbook** – Nigel Calder, 2001
- Books written before 2006 won't include some MGS anchors and modern ground tackle.

MGS Anchor Websites

- **Rocna Website** – www.rocna.com
- **Rocna Inventor Website** - www.petersmith.net.nz (BEST INFO)
- **Spade Website** - www.spadeanchor.co.uk
- **Manson Website** - www.manson-marine.co.nz
- **Ultra Website** - www.quickline.us
- **Mantus Website** – www.mantusanchors.com
- **Knox Website** - www.knoxanchors.com

Misc Anchor Research

- PBO – Anchors Aware! Anchors on Test, Dr. John Knox, Aug 2011
- Recent Anchor Test Summary -
<http://www.velerosgrecia.com/download/art%C3%A0Dculos/Independent%20Anchor%20Performance%20Testing.pdf>
- Morgan's Cloud Website -
<http://www.morganscloud.com/2011/11/23/rocna-versus-spade-anchors/>
- Blackwell's – Anchor Selection, 10/2013
http://cruising.coastalboating.net/Seamanship/Anchoring/Anchor_Selection/index.html#.UI-9wi4D1cQ.facebook

Recent Practical Sailor Info

- PS - Small Anchor Reset Tests, Feb 2013
- PS - Anchor Shank Testing, Apr 2013
- PS - Anchor Shank Bending, May 2013
- PS - It's a Stretch - Snubbers in Action, Nov 2013
- PS – Anchor Chain – Chain vs Fiber Rode, Feb 2014
- Many other articles

The End –Q & A



Dave & Sherry McCampbell

www.SVSoggypaws.com

Presentations link on home page